

# SIRIUS Detecting Product Overview of 3SE5 Position Switches



Brochure • November 2007

# low-voltage

CONTROLS AND DISTRIBUTION



# SIEMENS

## Precise and reliable: Our SIRIUS Detecting Devices

There is a lot of information in the field. To capture the data accurately, you need devices which you can rely on. Our comprehensive range of SIRIUS detecting devices is just what you need for nearly any field-level application. Our mechanical high-precision sensors dependably detect any motion sequence, convert the event into electrical signals and transmit the data to your control systems, so that you can immediately shut down your machines and systems if a fault occurs. Reliably and with everything under control.

### Always in step with developments: the complete range of detecting devices

Whatever information you need and no matter how you want to get it, our portfolio offers the right solution. From standard position switches in a plastic or metal enclosure for any conceivable standard or safety-related application, to position switches with short-stroke contact block for high-precision disconnect, and position switches with separate actuator or with solenoid interlocking, e.g. for the secure interlocking of protective doors.

We also offer a complete range of non-contact sensors to help you monitor the entire process in any application. Our portfolio includes optical sensors such as light curtains and laser scanners as well as our dependable family of proximity switches.

Whether you use the switches for standard functions or in safety circuits, no unexpected movement escapes our detecting devices no matter how harsh the conditions are. Positive-opening IEC 60947-5-1 compliant contacts are suitable for use as mechanical position switches in applications up to EN 954-1 Category 4.



# Contents

## Introduction

SIRIUS Detecting Devices . . . . .	2
------------------------------------	---

## Standard Position Switches

Plastic enclosures, 31 mm, according to EN 50047 . . . . .	8
Plastic enclosures, 50 mm . . . . .	12
Metal enclosures, 40 mm, according to EN 50041 . . . . .	16
Metal enclosures, 56 mm . . . . .	20
Open-type standard position switches . . . . .	24

## Safety Position Switches

With separate actuator . . . . .	26
With solenoid interlocking . . . . .	28
Hinge switches . . . . .	32

ASIsafe  . . . . .	33
---	----

ATEX . . . . .	42
----------------	----

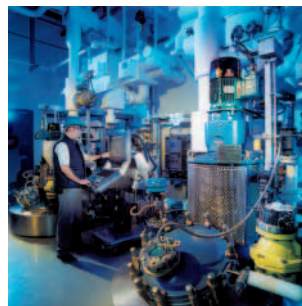

# Your Field Level Informants: SIRIUS Standard Position Switches

**SIRIUS standard position switches** give you the dependable performance you need in your everyday industrial applications thanks to their modular, consistent design with a wide choice of variants and enormous variety of operating mechanisms. If you are looking for a low-cost, durable solution for applications with less stringent safety requirements, for example to detect hazardous motion of machine parts or to monitor safety devices, SIRIUS standard position switches are just what you are looking for.

Standardized designs and functions make it easy for you to select the right switch, and they also facilitate simple, efficient stockage, installation, wiring and maintenance. Our wide range of products is designed for applications up to EN 954-1 Category 4 when you select the right product and use them properly in conjunction with fail-safe monitoring units such as the 3TK28, ASISafe, SIMATIC or SINUMERIK.

All modules/devices which have positive-opening code  can be used in safety circuits.

## New features

**Even more compact, modular, simple to connect:** Standard position switches have to offer more and more features. We have developed our new generation of SIRIUS standard position switches to meet market demands and offer you a whole series of advantages:

- **Modular design** with many standardized components reduces the number of variants, simplifies part stockage and increases the availability of spare parts.
- **Plug-in design** and a standardized interface simplify installation and replacement of the actuator heads.
- All **actuator heads can be rotated in 22.5° increments**.
- **Quick-connect technology on our plastic enclosures** according to EN 50047 (31 mm wide) **reduces installation time by up to 25 %**.
- The entire **ASISafe electronics are now integrated into the standard enclosure** – ASISafe now does not take up any extra space.
- **LED displays** are available **for all enclosures**, making it easier to perform on-site diagnosis (24 V DC and 115 – 230 V AC available).
- **The new 3-pole contact block** offers redundant disconnect and additional signaling for added safety, and it does not take up any more space than 2-pole contact blocks.
- Short-stroke contact blocks with 1 NO/1 NC improve the precision of switching operations.
- The 1 NO/1 NC snap-action contact with 2 x 2 mm contact opening is suitable for simultaneous disconnect and signaling in the elevator industry.

**The modular design of the new generation of standard position switches saves time and increases flexibility during installation of a whole range of switch variants.**

# The Advantages at a Glance

Easy plug-in method –  
for fast replacement of the actuator heads

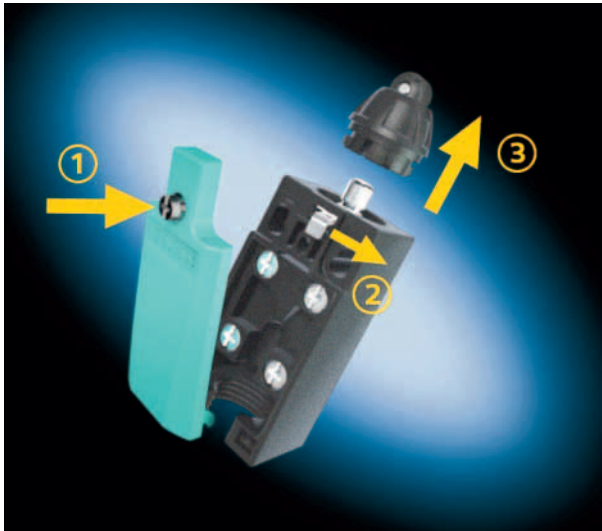

- ① Open the cover
- ② Actuate the locking lever
- ③ Replace the actuator head

ASIsafe electronics integrated in standard enclosure



Fast connection method for plastic enclosures



Optional LED displays for all enclosures



# Selection Criteria for Standard Position Switches

Enclosure designs			
	Enclosures	Degree of protection	Number of screw connections M20 x 1.5
	Open-type	IP20 (2-pole) IP10 (3-pole)	--
	Plastic enclosure, 31 mm wide, according to EN 50047	IP65	1
	Plastic enclosure, 50 mm wide	IP66, IP67	2 (suitable for looping through cables)
	Metal enclosure, 40 mm wide, according to EN 50041	IP66, IP67	1
	Metal enclosure, 56 mm wide	IP66, IP67	3 (suitable for looping through cables)
Contacts			
	Snap-action contact 1 NO/1 NC or 1 NO/2 NC	NC contacts and NO contacts switch at the same time regardless of the actuation speed	
	Slow-action contact 1 NO/1 NC or 1 NO/2 NC	Difference in travel between "NC contact opens" and "NO contact closes"; the switching speed is the same as or proportional to the actuation speed	
Actuators			
Please note:		<ul style="list-style-type: none"> <li>Direction of approach</li> <li>Actuation speed</li> <li>Form of actuating element</li> <li>Favorable material pair (actuator head - actuator)</li> </ul>	
		<b>Rounded plungers and roller plungers</b> <ul style="list-style-type: none"> <li>Operation in direction of the plunger axis or with bar at right angles to the plunger axis</li> <li>Rounded plungers and roller plungers have an additional overtravel and hence a larger operating distance</li> <li>The roller plunger is recommended for lateral actuation and relatively long overtravel</li> </ul>	
		<b>Roller levers and angular roller levers</b> <ul style="list-style-type: none"> <li>Depending on the direction of starting (left or right), various approach angles (<math>\alpha = 30^\circ</math>) and trailing angles (<math>\gamma = 45^\circ</math>) are possible</li> <li>For actuators made of finely ground steel in the form of cams, straight-edges or cam disks</li> </ul>	
		<b>Twist levers and rod actuators</b> <ul style="list-style-type: none"> <li>For a high starting speed (<math>v = 1.5</math> m/s)</li> <li>Variety of starting options</li> <li>Insensitive to oil, grinding dust, ice and coarse-grained material</li> <li>With the twist lever the maximum approach angle is always equal to the maximum trailing angle</li> <li>Rod actuator – when no actuator with approach and trailing angle is possible</li> <li>10° adjustment of the twist lever possible</li> </ul>	
		<b>Spring rods</b> <ul style="list-style-type: none"> <li>Can be used for undefined actuations and changing starting conditions</li> <li>Starting from any direction</li> </ul>	
		<b>Roller plungers for central fixing with M18 x 1 thread</b> <ul style="list-style-type: none"> <li>Fast assembly</li> <li>Easy adjustment</li> </ul>	
		<b>Fork levers</b> <ul style="list-style-type: none"> <li>Switchable in two directions</li> <li>Latching actuator</li> <li>For reciprocating movements</li> </ul>	

# Ordering Notes on Selection Tables for 3SE5 Position Switches

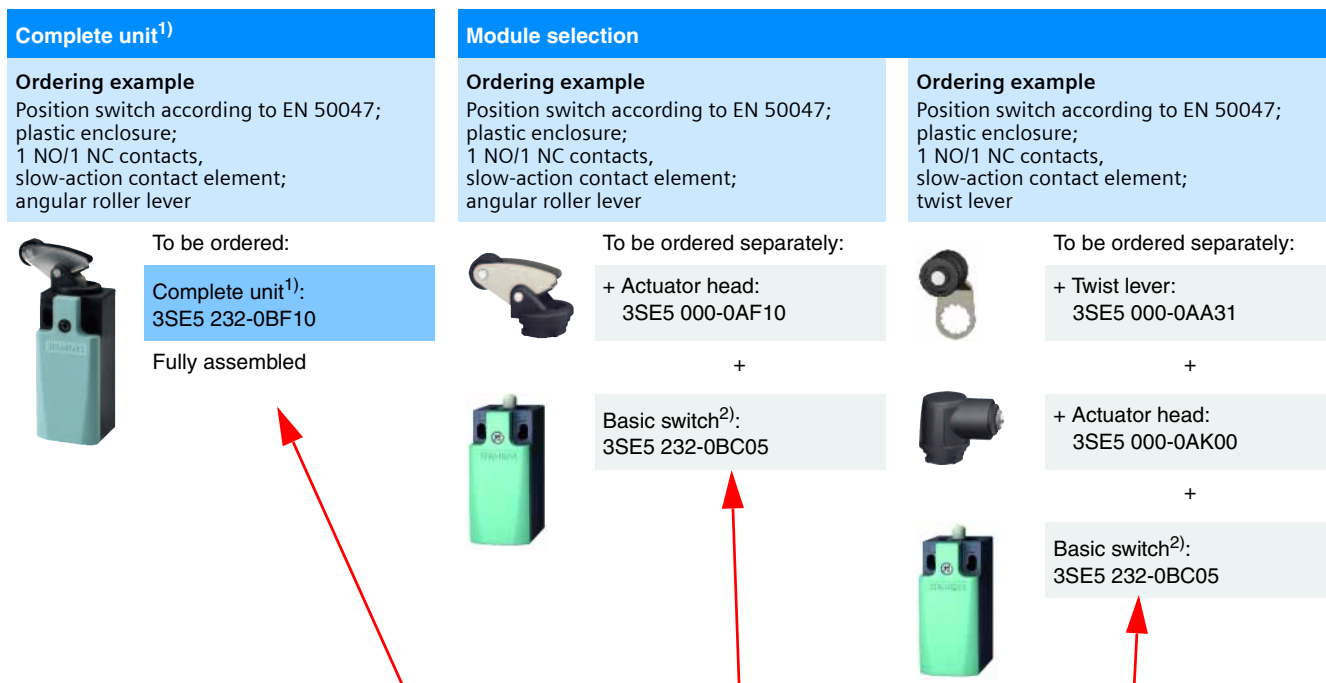

Excerpt from ordering table

Contact block		LED display	Connection	Angular roller levers		Twist levers according to EN 50047	
Con-tacts	Contact element			Metal levers	Plastic rollers	High-grade steel levers	Plastic rollers
1 NO/1 NC	Slow action	Without	1 x (M20 x 1.5)	Complete unit <sup>1)</sup>	↑ $v_{max} = 1 \text{ m/s}$ →	↔ $v_{max} = 1 \text{ m/s}$ →	--
				Basic switch <sup>2)</sup>	3SE5 232-0BC05	3SE5 232-0BC05	3SE5 232-0BC05
				+ Actuator head	3SE5 000-0AF10	3SE5 000-0AK00	3SE5 000-0AA31
				+ Twist lever	--	3SE5 000-0AA31	3SE5 000-0AA31

1) Each complete unit can also be ordered as a module.  
 2) A basic switch comprises an enclosure with contacts and a cover.

# Standard Position Switches Plastic Enclosures, 31 mm

Switching points and mounting according to EN 50047, IP65

Complete unit and  
Module selection



				Rounded plungers	Roller plungers			Roller levers			Angular roller levers				
				(Integrated in basic switch)											
				Teflon plungers	Plastic rollers	High-grade steel rollers	Plastic rollers, central fixing	Metal levers		High-grade steel levers	Metal levers	High-grade steel levers			
				↓ v <sub>max.</sub> = 1 m/s	↔ v <sub>max.</sub> = 1 m/s	↔ v <sub>max.</sub> = 1 m/s	↔ v <sub>max.</sub> = 1 m/s	← v <sub>max.</sub> = 1 m/s	← v <sub>max.</sub> = 1 m/s	← v <sub>max.</sub> = 1 m/s	↑ v <sub>max.</sub> = 1 m/s	↑ v <sub>max.</sub> = 1 m/s			
								Plastic rollers	High-grade steel rollers	Plastic rollers	Plastic rollers	Plastic rollers			
1 NO/ 1 NC	Slow action	without	1 x (M20 x 1.5)	Complete unit	3SE5 232-0BC05	3SE5 232-0BD03	--	--	3SE5 232-0BE10	--	--	3SE5 232-0BF10	--		
				Basic switch	--	3SE5 232-0BC05	3SE5 232-0BC05	3SE5 232-0BC05	3SE5 232-0BC05	3SE5 232-0BC05	3SE5 232-0BC05	3SE5 232-0BC05	3SE5 232-0BC05	3SE5 232-0BC05	
				+ Actuator head	--	3SE5 000-0AD03	3SE5 000-0AD04	3SE5 000-0AD10	3SE5 000-0AE10	3SE5 000-0AE11	3SE5 000-0AE12	3SE5 000-0AF10	3SE5 000-0AF12		
			M12 plug, 4-pole	Complete unit	3SE5 234-0BC05-1AC4	--	--	--	--	--	--	--	--	--	--
				Basic switch	--	3SE5 234-0BC05-1AC4	3SE5 234-0BC05-1AC4	3SE5 234-0BC05-1AC4	3SE5 234-0BC05-1AC4	3SE5 234-0BC05-1AC4	3SE5 234-0BC05-1AC4	3SE5 234-0BC05-1AC4	3SE5 234-0BC05-1AC4	3SE5 234-0BC05-1AC4	3SE5 234-0BC05-1AC4
				+ Actuator head	--	3SE5 000-0AD03	3SE5 000-0AD04	3SE5 000-0AD10	3SE5 000-0AE10	3SE5 000-0AE11	3SE5 000-0AE12	3SE5 000-0AF10	3SE5 000-0AF12		
	Snap action integrated, not replaceable	without	1 x (M20 x 1.5)	Complete unit	3SE5 232-0HC05	3SE5 232-0HD03	--	3SE5 232-0HD10	3SE5 232-0HE10	--	--	3SE5 232-0HF10	--		
				Basic switch	--	3SE5 232-0HC05	3SE5 232-0HC05	3SE5 232-0HC05	3SE5 232-0HC05	3SE5 232-0HC05	3SE5 232-0HC05	3SE5 232-0HC05	3SE5 232-0HC05		
				+ Actuator head	--	3SE5 000-0AD03	3SE5 000-0AD04	3SE5 000-0AD10	3SE5 000-0AE10	3SE5 000-0AE11	3SE5 000-0AE12	3SE5 000-0AF10	3SE5 000-0AF12		
		M12 plug, 4-pole	Complete unit	3SE5 234-0HC05-1AC4	3SE5 234-0HD03-1AC4	--	--	3SE5 234-0HE10-1AC4	--	--	--	--	--		
			Basic switch	--	3SE5 234-0HC05-1AC4	3SE5 234-0HC05-1AC4	3SE5 234-0HC05-1AC4	3SE5 234-0HC05-1AC4	3SE5 234-0HC05-1AC4	3SE5 234-0HC05-1AC4	3SE5 234-0HC05-1AC4	3SE5 234-0HC05-1AC4	3SE5 234-0HC05-1AC4		
			+ Actuator head	--	3SE5 000-0AD03	3SE5 000-0AD04	3SE5 000-0AD10	3SE5 000-0AE10	3SE5 000-0AE11	3SE5 000-0AE12	3SE5 000-0AF10	3SE5 000-0AF12			
Snap action, short stroke, not replaceable	without	1 x (M20 x 1.5)	Complete unit	3SE5 232-0FC05	--	--	--	--	--	--	--	--			
			Basic switch	--	3SE5 232-0FC05	3SE5 232-0FC05	3SE5 232-0FC05	3SE5 232-0FC05	3SE5 232-0FC05	3SE5 232-0FC05	3SE5 232-0FC05	3SE5 232-0FC05			
			+ Actuator head	--	3SE5 000-0AD03	3SE5 000-0AD04	3SE5 000-0AD10	3SE5 000-0AE10	3SE5 000-0AE11	3SE5 000-0AE12	3SE5 000-0AF10	3SE5 000-0AF12			
1 NO/ 2 NC	Slow-action contact	without	1 x (M20 x 1.5)	Complete unit	3SE5 232-0KC05	3SE5 232-0KD03	--	3SE5 232-0KD10	3SE5 232-0KE10	--	--	3SE5 232-0KF10	--		
				Basic switch	--	3SE5 232-0KC05	3SE5 232-0KC05	3SE5 232-0KC05	3SE5 232-0KC05	3SE5 232-0KC05	3SE5 232-0KC05	3SE5 232-0KC05	3SE5 232-0KC05		
				+ Actuator head	--	3SE5 000-0AD03	3SE5 000-0A04	3SE5 000-0AD10	3SE5 000-0AE10	3SE5 000-0AE11	3SE5 000-0AE12	3SE5 000-0AF10	3SE5 000-0AF12		
			M12 plug, 4-pole (2 NC connected)	Complete unit	3SE5 234-0KC05-1AE0	--	--	--	--	--	--	--	--	--	
				Basic switch	--	3SE5 234-0KC05-1AE0	3SE5 234-0KC05-1AE0	3SE5 234-0KC05-1AE0	3SE5 234-0KC05-1AE0	3SE5 234-0KC05-1AE0	3SE5 234-0KC05-1AE0	3SE5 234-0KC05-1AE0	3SE5 234-0KC05-1AE0	3SE5 234-0KC05-1AE0	
				+ Actuator head	--	3SE5 000-0AD03	3SE5 000-0AD04	3SE5 000-0AD10	3SE5 000-0AE10	3SE5 000-0AE11	3SE5 000-0AE12	3SE5 000-0AF10	3SE5 000-0AF12		
	Snap-action contact	without	1 x (M20 x 1.5)	Complete unit	3SE5 232-0LC05	3SE5 232-0LD03	--	--	3SE5 232-0LE10	--	--	3SE5 232-0LF10	--		
				Basic switch	--	3SE5 232-0LC05	3SE5 232-0LC05	3SE5 232-0LC05	3SE5 232-0LC05	3SE5 232-0LC05	3SE5 232-0LC05	3SE5 232-0LC05	3SE5 232-0LC05		
				+ Actuator head	--	3SE5 000-0AD03	3SE5 000-0AD04	3SE5 000-0AD10	3SE5 000-0AE10	3SE5 000-0AE11	3SE5 000-0AE12	3SE5 000-0AF10	3SE5 000-0AF12		
		2 LEDs, yellow / green 24 V DC	Complete unit	3SE5 232-1LC05	--	--	--	--	--	--	--	--	--		
			Basic switch	--	3SE5 232-1LC05	3SE5 232-1LC05	3SE5 232-1LC05	3SE5 232-1LC05	3SE5 232-1LC05	3SE5 232-1LC05	3SE5 232-1LC05	3SE5 232-1LC05			
			+ Actuator head	--	3SE5 000-0AD03	3SE5 000-0AD04	3SE5 000-0AD10	3SE5 000-0AE10	3SE5 000-0AE11	3SE5 000-0AE12	3SE5 000-0AF10	3SE5 000-0AF12			
without	M12 plug, 4-pole (2 NC connected)	Complete unit	3SE5 234-0LC05-1AE0	--	--	--	--	--	--	--	--				
		Basic switch	--	3SE5 234-0LC05-1AE0	3SE5 234-0LC05-1AE0	3SE5 234-0LC05-1AE0	3SE5 234-0LC05-1AE0	3SE5 234-0LC05-1AE0	3SE5 234-0LC05-1AE0	3SE5 234-0LC05-1AE0	3SE5 234-0LC05-1AE0				
		+ Actuator head	--	3SE5 000-0AD03	3SE5 000-0AD04	3SE5 000-0AD10	3SE5 000-0AE10	3SE5 000-0AE11	3SE5 000-0AE12	3SE5 000-0AF10	3SE5 000-0AF12				

For ordering notes see page 7.



# Standard Position Switches Plastic Enclosures, 31 mm

Switching points and mounting according to EN 50047, IP65

Complete unit and Module selection

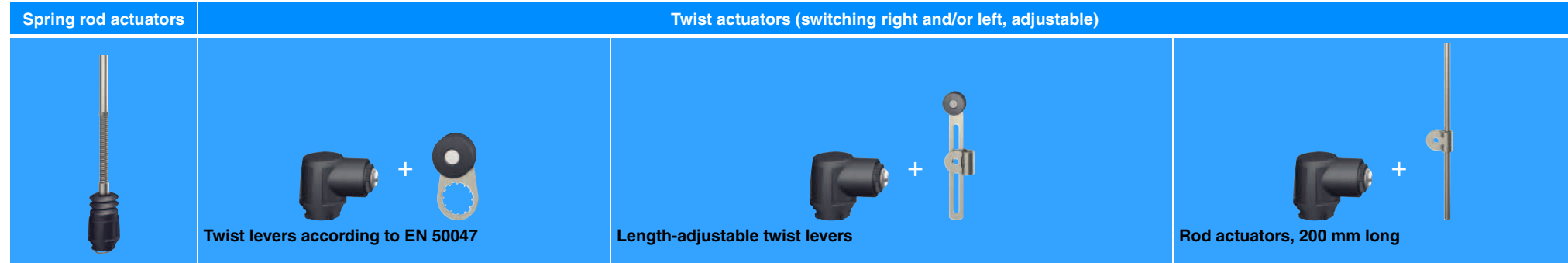

Contact block		LED display	Connection		Spring rod actuators	Twist actuators (switching right and/or left, adjustable)								
Contacts	Contact element				Plastic plungers, total length 143 mm $v_{max.} = 1 \text{ m/s}$	Metal levers Plastic rollers $\leftrightarrow v_{max.} = 1,5 \text{ m/s}$	High-grade steel levers Plastic rollers $\leftrightarrow v_{max.} = 1,5 \text{ m/s}$	Metal levers Plastic rollers $\leftrightarrow v_{max.} = 1,5 \text{ m/s}$	High-grade steel rollers $\leftrightarrow v_{max.} = 1,5 \text{ m/s}$	With latching holes, plastic rollers $\leftrightarrow v_{max.} = 1,5 \text{ m/s}$	Aluminum $\leftrightarrow v_{max.} = 1,5 \text{ m/s}$	Plastic $\leftrightarrow v_{max.} = 1,5 \text{ m/s}$		
1 NO/ 1 NC	Slow action	without	1 x (M20 x 1.5)	Complete unit	--	3SE5 232-0BK21	--	3SE5 232-0BK50	--	--	--	--		
				Basic switch	--	3SE5 232-0BC05	3SE5 232-0BC05	3SE5 232-0BC05	3SE5 232-0BC05	3SE5 232-0BC05	3SE5 232-0BC05	3SE5 232-0BC05	3SE5 232-0BC05	
				+ Actuator head	--	3SE5 000-0AK00	3SE5 000-0AK00	3SE5 000-0AK00	3SE5 000-0AK00	3SE5 000-0AK00	3SE5 000-0AK00	3SE5 000-0AK00	3SE5 000-0AK00	
			M12 plug, 4-pole	Complete unit	--	--	--	--	--	--	--	--	--	--
				Basic switch	--	3SE5 234-0BC05-1AC4	3SE5 234-0BC05-1AC4	3SE5 234-0BC05-1AC4	3SE5 234-0BC05-1AC4	3SE5 234-0BC05-1AC4	3SE5 234-0BC05-1AC4	3SE5 234-0BC05-1AC4	3SE5 234-0BC05-1AC4	3SE5 234-0BC05-1AC4
				+ Actuator head	--	3SE5 000-0AK00	3SE5 000-0AK00	3SE5 000-0AK00	3SE5 000-0AK00	3SE5 000-0AK00	3SE5 000-0AK00	3SE5 000-0AK00	3SE5 000-0AK00	3SE5 000-0AK00
	Snap action integrated, not replaceable	without	1 x (M20 x 1.5)	Complete unit	3SE5 232-0HR01	3SE5 232-0HK21	--	3SE5 232-0HK50	--	3SE5 232-0HK60	3SE5 232-0HK80	3SE5 232-0HK82		
				Basic switch	3SE5 232-0HC05	3SE5 232-0HC05	3SE5 232-0HC05	3SE5 232-0HC05	3SE5 232-0HC05	3SE5 232-0HC05	3SE5 232-0HC05	3SE5 232-0HC05	3SE5 232-0HC05	
				+ Actuator head	3SE5 000-0AR01	3SE5 000-0AK00	3SE5 000-0AK00	3SE5 000-0AK00	3SE5 000-0AK00	3SE5 000-0AK00	3SE5 000-0AK00	3SE5 000-0AK00	3SE5 000-0AK00	
		M12 plug, 4-pole	Complete unit	--	3SE5 234-0HK21-1AC4	--	--	--	--	--	--	--		
			Basic switch	3SE5 234-0HC05-1AC4	3SE5 234-0HC05-1AC4	3SE5 234-0HC05-1AC4	3SE5 234-0HC05-1AC4	3SE5 234-0HC05-1AC4	3SE5 234-0HC05-1AC4	3SE5 234-0HC05-1AC4	3SE5 234-0HC05-1AC4	3SE5 234-0HC05-1AC4		
			+ Actuator head	3SE5 000-0AR01	3SE5 000-0AK00	3SE5 000-0AK00	3SE5 000-0AK00	3SE5 000-0AK00	3SE5 000-0AK00	3SE5 000-0AK00	3SE5 000-0AK00	3SE5 000-0AK00		
Snap action, short stroke, not replaceable	without	1 x (M20 x 1.5)	Complete unit	--	--	--	--	--	--	--	--			
			Basic switch	3SE5 232-0FC05	3SE5 232-0FC05	3SE5 232-0FC05	3SE5 232-0FC05	3SE5 232-0FC05	3SE5 232-0FC05	3SE5 232-0FC05	3SE5 232-0FC05	3SE5 232-0FC05		
			+ Actuator head	3SE5 000-0AR01	3SE5 000-0AK00	3SE5 000-0AK00	3SE5 000-0AK00	3SE5 000-0AK00	3SE5 000-0AK00	3SE5 000-0AK00	3SE5 000-0AK00	3SE5 000-0AK00		
			+ Twist lever	--	3SE5 000-0AA21	3SE5 000-0AA31	3SE5 000-0AA50	3SE5 000-0AA51	3SE5 000-0AA60	3SE5 000-0AA80	3SE5 000-0AA82			
			1 NO/ 2 NC	Slow action	without	1 x (M20 x 1.5)	Complete unit	--	3SE5 232-0KK21	--	--	--	--	--
							Basic switch	--	3SE5 232-0KC05	3SE5 232-0KC05	3SE5 232-0KC05	3SE5 232-0KC05	3SE5 232-0KC05	3SE5 232-0KC05
+ Actuator head	--	3SE5 000-0AK00					3SE5 000-0AK00	3SE5 000-0AK00	3SE5 000-0AK00	3SE5 000-0AK00	3SE5 000-0AK00	3SE5 000-0AK00		
M12 plug, 4-pole (2 NC connected)	Complete unit	--			--	--	--	--	--	--	--	--		
	Basic switch	--			3SE5 234-0KC05-1AE0	3SE5 234-0KC05-1AE0	3SE5 234-0KC05-1AE0	3SE5 234-0KC05-1AE0	3SE5 234-0KC05-1AE0	3SE5 234-0KC05-1AE0	3SE5 234-0KC05-1AE0	3SE5 234-0KC05-1AE0		
	+ Actuator head	--			3SE5 000-0AK00	3SE5 000-0AK00	3SE5 000-0AK00	3SE5 000-0AK00	3SE5 000-0AK00	3SE5 000-0AK00	3SE5 000-0AK00	3SE5 000-0AK00		
Snap action	without	1 x (M20 x 1.5)	Complete unit	--	3SE5 232-0LK21	--	3SE5 232-0LK50	--	--	--	--			
			Basic switch	3SE5 232-0LC05	3SE5 232-0LC05	3SE5 232-0LC05	3SE5 232-0LC05	3SE5 232-0LC05	3SE5 232-0LC05	3SE5 232-0LC05	3SE5 232-0LC05			
			+ Actuator head	3SE5 000-0AR01	3SE5 000-0AK00	3SE5 000-0AK00	3SE5 000-0AK00	3SE5 000-0AK00	3SE5 000-0AK00	3SE5 000-0AK00	3SE5 000-0AK00			
	2 LEDs, yellow / green 24 V DC	Complete unit	--	--	--	--	--	--	--	--	--			
		Basic switch	3SE5 232-1LC05	3SE5 232-1LC05	3SE5 232-1LC05	3SE5 232-1LC05	3SE5 232-1LC05	3SE5 232-1LC05	3SE5 232-1LC05	3SE5 232-1LC05	3SE5 232-1LC05			
		+ Actuator head	3SE5 000-0AR01	3SE5 000-0AK00	3SE5 000-0AK00	3SE5 000-0AK00	3SE5 000-0AK00	3SE5 000-0AK00	3SE5 000-0AK00	3SE5 000-0AK00	3SE5 000-0AK00			
without	M12 plug, 4-pole (2 NC connected)	Complete unit	--	--	--	--	--	--	--	--				
		Basic switch	3SE5 234-0LC05-1AE0	3SE5 234-0LC05-1AE0	3SE5 234-0LC05-1AE0	3SE5 234-0LC05-1AE0	3SE5 234-0LC05-1AE0	3SE5 234-0LC05-1AE0	3SE5 234-0LC05-1AE0	3SE5 234-0LC05-1AE0				
		+ Actuator head	3SE5 000-0AR01	3SE5 000-0AK00	3SE5 000-0AK00	3SE5 000-0AK00	3SE5 000-0AK00	3SE5 000-0AK00	3SE5 000-0AK00	3SE5 000-0AK00				

For ordering notes see page 7.

# Standard Position Switches

## Plastic Enclosures, 50 mm

Switching points according to EN 50047, IP66/IP67



Complete unit and Module selection

Contact block		LED display	Connection		
Contacts	Contact element				
1 NO/ 1 NC	Slow action	without	2 x (M20 x 1.5)		
				Complete unit	
				Basic switch	
	Snap action, not replaceable	without	2 x (M20 x 1.5)	Complete unit	
				Basic switch	
				+ Actuator head	
	Snap action, short stroke, not replaceable	without	2 x (M20 x 1.5)	Complete unit	
				Basic switch	
				+ Actuator head	
1 NO/ 2 NC	Slow action	without	2 x (M20 x 1.5)	Complete unit	
				Basic switch	
				+ Actuator head	
				2 LEDs, yellow / green, 24 V DC	Complete unit
					Basic switch
					+ Actuator head
	Snap action	without	2 x (M20 x 1.5)	Complete unit	
				Basic switch	
				+ Actuator head	
				2 LEDs, yellow / green, 24 V DC	Complete unit
					Basic switch
					+ Actuator head

Rounded plungers	Roller plungers			Roller levers		Angular roller levers		
(Integrated in basic switch)								
Teflon plungers	Plastic rollers	High-grade steel rollers	Plastic rollers, central fixing	Metal levers	High-grade steel levers	Metal levers	High-grade steel levers	
↓ v <sub>max.</sub> = 1 m/s	↔ v <sub>max.</sub> = 1 m/s	↔ v <sub>max.</sub> = 1 m/s	↔ v <sub>max.</sub> = 1 m/s	← v <sub>max.</sub> = 1 m/s	← v <sub>max.</sub> = 1 m/s	↑ v <sub>max.</sub> = 1 m/s	↑ v <sub>max.</sub> = 1 m/s	
	Plastic rollers	High-grade steel rollers	Plastic rollers	Plastic rollers	Plastic rollers	Plastic rollers	Plastic rollers	
Complete unit	3SE5 242-0BC05	3SE5 242-0BD03	--	--	3SE5 242-0BE10	--	--	
	Basic switch	3SE5 242-0BC05	3SE5 242-0BC05	3SE5 242-0BC05	3SE5 242-0BC05	3SE5 242-0BC05	3SE5 242-0BC05	
	+ Actuator head	3SE5 000-0AD03	3SE5 000-0AD04	3SE5 000-0AD10	3SE5 000-0AE10	3SE5 000-0AE12	3SE5 000-0AF10	
Complete unit	3SE5 242-0HC05	3SE5 242-0HD03	--	--	3SE5 242-0HE10	--	--	
	Basic switch	3SE5 242-0HC05	3SE5 242-0HC05	3SE5 242-0HC05	3SE5 242-0HC05	3SE5 242-0HC05	3SE5 242-0HC05	
	+ Actuator head	3SE5 000-0AD03	3SE5 000-0AD04	3SE5 000-0AD10	3SE5 000-0AE10	3SE5 000-0AE12	3SE5 000-0AF10	
Complete unit	3SE5 242-0FC05	--	--	--	--	--	--	
	Basic switch	3SE5 242-0FC05	3SE5 242-0FC05	3SE5 242-0FC05	3SE5 242-0FC05	3SE5 242-0FC05	3SE5 242-0FC05	
	+ Actuator head	3SE5 000-0AD03	3SE5 000-0AD04	3SE5 000-0AD10	3SE5 000-0AE10	3SE5 000-0AE12	3SE5 000-0AF10	
Complete unit	3SE5 242-0KC05	--	--	--	--	--	--	
	Basic switch	3SE5 242-0KC05	3SE5 242-0KC05	3SE5 242-0KC05	3SE5 242-0KC05	3SE5 242-0KC05	3SE5 242-0KC05	
	+ Actuator head	3SE5 000-0AD03	3SE5 000-0AD04	3SE5 000-0AD10	3SE5 000-0AE10	3SE5 000-0AE12	3SE5 000-0AF10	
	Complete unit	3SE5 242-1KC05	--	--	--	--	--	--
		Basic switch	3SE5 242-1KC05	3SE5 242-1KC05	3SE5 242-1KC05	3SE5 242-1KC05	3SE5 242-1KC05	3SE5 242-1KC05
		+ Actuator head	3SE5 000-0AD03	3SE5 000-0AD04	3SE5 000-0AD10	3SE5 000-0AE10	3SE5 000-0AE12	3SE5 000-0AF10
Complete unit	3SE5 242-0LC05	3SE5 242-0LD03	--	--	3SE5 242-0LE10	--	--	
	Basic switch	3SE5 242-0LC05	3SE5 242-0LC05	3SE5 242-0LC05	3SE5 242-0LC05	3SE5 242-0LC05	3SE5 242-0LC05	
	+ Actuator head	3SE5 000-0AD03	3SE5 000-0AD04	3SE5 000-0AD10	3SE5 000-0AE10	3SE5 000-0AE12	3SE5 000-0AF10	
	Complete unit	3SE5 242-1LC05	--	--	--	--	--	--
		Basic switch	3SE5 242-1LC05	3SE5 242-1LC05	3SE5 242-1LC05	3SE5 242-1LC05	3SE5 242-1LC05	3SE5 242-1LC05
		+ Actuator head	3SE5 000-0AD03	3SE5 000-0AD04	3SE5 000-0AD10	3SE5 000-0AE10	3SE5 000-0AE12	3SE5 000-0AF10

For ordering notes see page 7.

Standard Position Switches  
Plastic Enclosures, 50 mm  
Switching points according to EN 50047, IP66/IP67

Complete unit and Module selection



				Spring rod actuators	Twist actuators (switching right and/or left, adjustable)										
				Plastic plungers, total length 143 mm $v_{max.} = 1 \text{ m/s}$	Metal levers		High-grade steel levers	Metal levers			Aluminum	Plastic			
					Plastic rollers	Plastic rollers	Plastic rollers	High-grade steel rollers	With latching holes, plastic rollers						
Contact block	LED display	Connection	Contacts	Complete unit	$v_{max.} = 1,5 \text{ m/s}$ →	↔ $v_{max.} = 1,5 \text{ m/s}$ ↔	↔ $v_{max.} = 1,5 \text{ m/s}$ ↔	↔ $v_{max.} = 1,5 \text{ m/s}$ ↔	↔ $v_{max.} = 1,5 \text{ m/s}$	↔ $v_{max.} = 1,5 \text{ m/s}$ ↔	↔ $v_{max.} = 1 \text{ m/s}$	↔ $v_{max.} = 1 \text{ m/s}$			
1 NO/ 1 NC	Slow action	without	2 x (M20 x 1.5)	Complete unit	--	--	--	--	--	--	--	--			
				Basic switch	3SE5 242-0BC05	3SE5 242-0BC05	3SE5 242-0BC05	3SE5 242-0BC05	3SE5 242-0BC05	3SE5 242-0BC05	3SE5 242-0BC05	3SE5 242-0BC05	3SE5 242-0BC05	3SE5 242-0BC05	
				+ Actuator head	3SE5 000-0AR01	3SE5 000-0AK00	3SE5 000-0AK00	3SE5 000-0AK00	3SE5 000-0AK00	3SE5 000-0AK00	3SE5 000-0AK00	3SE5 000-0AK00	3SE5 000-0AK00	3SE5 000-0AK00	
				+ Twist lever	--	3SE5 000-0AA21	3SE5 000-0AA31	3SE5 000-0AA50	3SE5 000-0AA51	3SE5 000-0AA60	3SE5 000-0AA80	3SE5 000-0AA82			
				Complete unit	--	3SE5 242-0HK21	--	3SE5 242-0HK50	--	--	--	--	--	--	
				Basic switch	3SE5 242-0HC05	3SE5 242-0HC05	3SE5 242-0HC05	3SE5 242-0HC05	3SE5 242-0HC05	3SE5 242-0HC05	3SE5 242-0HC05	3SE5 242-0HC05	3SE5 242-0HC05	3SE5 242-0HC05	3SE5 242-0HC05
	Snap action, not replaceable	without	2 x (M20 x 1.5)	2 x (M20 x 1.5)	Complete unit	--	--	--	--	--	--	--	--		
					Basic switch	3SE5 242-0HC05	3SE5 242-0HC05	3SE5 242-0HC05	3SE5 242-0HC05	3SE5 242-0HC05	3SE5 242-0HC05	3SE5 242-0HC05	3SE5 242-0HC05	3SE5 242-0HC05	3SE5 242-0HC05
					+ Actuator head	3SE5 000-0AR01	3SE5 000-0AK00	3SE5 000-0AK00	3SE5 000-0AK00	3SE5 000-0AK00	3SE5 000-0AK00	3SE5 000-0AK00	3SE5 000-0AK00	3SE5 000-0AK00	3SE5 000-0AK00
					+ Twist lever	--	3SE5 000-0AA21	3SE5 000-0AA31	3SE5 000-0AA50	3SE5 000-0AA51	3SE5 000-0AA60	3SE5 000-0AA80	3SE5 000-0AA82		
					Complete unit	--	--	--	--	--	--	--	--	--	--
					Basic switch	3SE5 242-0FC05	3SE5 242-0FC05	3SE5 242-0FC05	3SE5 242-0FC05	3SE5 242-0FC05	3SE5 242-0FC05	3SE5 242-0FC05	3SE5 242-0FC05	3SE5 242-0FC05	3SE5 242-0FC05
1 NO/ 2 NC	Slow action	without	2 x (M20 x 1.5)	Complete unit	--	--	--	--	--	--	--	--			
				Basic switch	3SE5 242-0KC05	3SE5 242-0KC05	3SE5 242-0KC05	3SE5 242-0KC05	3SE5 242-0KC05	3SE5 242-0KC05	3SE5 242-0KC05	3SE5 242-0KC05	3SE5 242-0KC05	3SE5 242-0KC05	
				+ Actuator head	3SE5 000-0AR01	3SE5 000-0AK00	3SE5 000-0AK00	3SE5 000-0AK00	3SE5 000-0AK00	3SE5 000-0AK00	3SE5 000-0AK00	3SE5 000-0AK00	3SE5 000-0AK00	3SE5 000-0AK00	
				+ Twist lever	--	3SE5 000-0AA21	3SE5 000-0AA31	3SE5 000-0AA50	3SE5 000-0AA51	3SE5 000-0AA60	3SE5 000-0AA80	3SE5 000-0AA82			
				Complete unit	--	--	--	--	--	--	--	--	--	--	
				Basic switch	3SE5 242-1KC05	3SE5 242-1KC05	3SE5 242-1KC05	3SE5 242-1KC05	3SE5 242-1KC05	3SE5 242-1KC05	3SE5 242-1KC05	3SE5 242-1KC05	3SE5 242-1KC05	3SE5 242-1KC05	3SE5 242-1KC05
	Snap action	without	2 x (M20 x 1.5)	2 x (M20 x 1.5)	Complete unit	--	--	--	--	--	--	--	--		
					Basic switch	3SE5 242-0LC05	3SE5 242-0LC05	3SE5 242-0LC05	3SE5 242-0LC05	3SE5 242-0LC05	3SE5 242-0LC05	3SE5 242-0LC05	3SE5 242-0LC05	3SE5 242-0LC05	3SE5 242-0LC05
					+ Actuator head	3SE5 000-0AR01	3SE5 000-0AK00	3SE5 000-0AK00	3SE5 000-0AK00	3SE5 000-0AK00	3SE5 000-0AK00	3SE5 000-0AK00	3SE5 000-0AK00	3SE5 000-0AK00	3SE5 000-0AK00
					+ Twist lever	--	3SE5 000-0AA21	3SE5 000-0AA31	3SE5 000-0AA50	3SE5 000-0AA51	3SE5 000-0AA60	3SE5 000-0AA80	3SE5 000-0AA82		
					Complete unit	--	--	--	--	--	--	--	--	--	--
					Basic switch	3SE5 242-1LC05	3SE5 242-1LC05	3SE5 242-1LC05	3SE5 242-1LC05	3SE5 242-1LC05	3SE5 242-1LC05	3SE5 242-1LC05	3SE5 242-1LC05	3SE5 242-1LC05	3SE5 242-1LC05
Snap action	2 LEDs, yellow / green, 24 V DC	without	2 x (M20 x 1.5)	Complete unit	--	--	--	--	--	--	--	--			
				Basic switch	3SE5 242-1LC05	3SE5 242-1LC05	3SE5 242-1LC05	3SE5 242-1LC05	3SE5 242-1LC05	3SE5 242-1LC05	3SE5 242-1LC05	3SE5 242-1LC05	3SE5 242-1LC05	3SE5 242-1LC05	
				+ Actuator head	3SE5 000-0AR01	3SE5 000-0AK00	3SE5 000-0AK00	3SE5 000-0AK00	3SE5 000-0AK00	3SE5 000-0AK00	3SE5 000-0AK00	3SE5 000-0AK00	3SE5 000-0AK00	3SE5 000-0AK00	
				+ Twist lever	--	3SE5 000-0AA21	3SE5 000-0AA31	3SE5 000-0AA50	3SE5 000-0AA51	3SE5 000-0AA60	3SE5 000-0AA80	3SE5 000-0AA82			
				Complete unit	--	--	--	--	--	--	--	--	--	--	
				Basic switch	3SE5 242-1LC05	3SE5 242-1LC05	3SE5 242-1LC05	3SE5 242-1LC05	3SE5 242-1LC05	3SE5 242-1LC05	3SE5 242-1LC05	3SE5 242-1LC05	3SE5 242-1LC05	3SE5 242-1LC05	3SE5 242-1LC05

For ordering notes see page 7.

## Standard Position Switches Metal Enclosures, 40 mm

Switching points according to  
EN 50041, IP66/IP67

Complete unit and  
Module selection



				Rounded plungers	Roller plungers	Roller levers	Angular roller levers		Spring rod actuators					
				High-grade steel plungers, with overtravel $\downarrow v_{max.} = 1 \text{ m/s}$	High-grade steel rollers $\leftrightarrow v_{max.} = 1 \text{ m/s}$	Metal levers Plastic rollers $\leftarrow v_{max.} = 1 \text{ m/s}$	High-grade steel rollers $\leftarrow v_{max.} = 1 \text{ m/s}$	Plastic rollers $\uparrow v_{max.} = 1 \text{ m/s}$	High-grade steel rollers $\uparrow v_{max.} = 1 \text{ m/s}$	Plastic plungers, total length 143 mm $v_{max.} = 1 \text{ m/s}$				
Contact block	LED display	Connection	Contacts	Contact element										
1 NO/ 1 NC	without	1 x (M20 x 1.5)	Slow action	Complete unit	3SE5 112-0BC02	3SE5 112-0BD02	3SE5 112-0BE01	--	3SE5 112-0BF01	--	--			
				Basic switch	3SE5 112-0BA00	3SE5 112-0BA00	3SE5 112-0BA00	3SE5 112-0BA00	3SE5 112-0BA00	3SE5 112-0BA00	--			
				+ Actuator head	3SE5 000-0AC02	3SE5 000-0AD02	3SE5 000-0AE01	3SE5 000-0AE02	3SE5 000-0AF01	3SE5 000-0AF02	--			
				M12 plug, 5-pole (PE connected)	Complete unit	--	--	--	--	--	--	--		
				Basic switch	3SE5 114-0BA00-1AC5	3SE5 114-0BA00-1AC5	3SE5 114-0BA00-1AC5	3SE5 114-0BA00-1AC5	3SE5 114-0BA00-1AC5	3SE5 114-0BA00-1AC5	--			
				+ Actuator head	3SE5 000-0AC02	3SE5 000-0AD02	3SE5 000-0AE01	3SE5 000-0AE02	3SE5 000-0AF01	3SE5 000-0AF02	--			
				Snap action	without	1 x (M20 x 1.5)	Complete unit	3SE5 112-0CC02	3SE5 112-0CD02	3SE5 112-0CE01	--	3SE5 112-0CF01	--	3SE5 112-0CR01
							Basic switch	3SE5 112-0CA00	3SE5 112-0CA00	3SE5 112-0CA00	3SE5 112-0CA00	3SE5 112-0CA00	3SE5 112-0CA00	3SE5 112-0CA00
							+ Actuator head	3SE5 000-0AC02	3SE5 000-0AD02	3SE5 000-0AE01	3SE5 000-0AE02	3SE5 000-0AF01	3SE5 000-0AF02	3SE5 000-0AR01
	M12 plug, 5-pole (PE connected)	Complete unit	--				--	--	--	--	--	--		
	Basic switch	3SE5 114-0CA00-1AC5	3SE5 114-0CA00-1AC5				3SE5 114-0CA00-1AC5	3SE5 114-0CA00-1AC5	3SE5 114-0CA00-1AC5	3SE5 114-0CA00-1AC5	3SE5 114-0CA00-1AC5			
	+ Actuator head	3SE5 000-0AC02	3SE5 000-0AD02				3SE5 000-0AE01	3SE5 000-0AE02	3SE5 000-0AF01	3SE5 000-0AF02	3SE5 000-0AR01			
	2 LEDs, yellow / green, 24 V DC	M12 plug, 5-pole	Complete unit				--	--	--	--	--	--	--	
			Basic switch				3SE5 114-1CA00-1AF3	3SE5 114-1CA00-1AF3	3SE5 114-1CA00-1AF3	3SE5 114-1CA00-1AF3	3SE5 114-1CA00-1AF3	3SE5 114-1CA00-1AF3	3SE5 114-1CA00-1AF3	
			+ Actuator head				3SE5 000-0AC02	3SE5 000-0AD02	3SE5 000-0AE01	3SE5 000-0AE02	3SE5 000-0AF01	3SE5 000-0AF02	3SE5 000-0AR01	
	1 NO/ 2 NC	without	1 x (M20 x 1.5)	Slow action	Complete unit	3SE5 112-0KC02	3SE5 112-0KD02	3SE5 112-0KE01	--	--	--	--		
					Basic switch	3SE5 112-0KA00	3SE5 112-0KA00	3SE5 112-0KA00	3SE5 112-0KA00	3SE5 112-0KA00	3SE5 112-0KA00	--		
					+ Actuator head	3SE5 000-0AC02	3SE5 000-0AD02	3SE5 000-0AE01	3SE5 000-0AE02	3SE5 000-0AF01	3SE5 000-0AF02	--		
M12 plug, 5-pole (2 NC, PE connected)					Complete unit	--	--	--	--	--	--	--		
Basic switch					3SE5 114-0KA00-1AE1	3SE5 114-0KA00-1AE1	3SE5 114-0KA00-1AE1	3SE5 114-0KA00-1AE1	3SE5 114-0KA00-1AE1	3SE5 114-0KA00-1AE1	--			
+ Actuator head					3SE5 000-0AC02	3SE5 000-0AD02	3SE5 000-0AE01	3SE5 000-0AE02	3SE5 000-0AF01	3SE5 000-0AF02	--			
Snap action					without	1 x (M20 x 1.5)	Complete unit	3SE5 112-0LC02	3SE5 112-0LD02	3SE5 112-0LE01	--	3SE5 112-0LF01	--	--
							Basic switch	3SE5 112-0LA00	3SE5 112-0LA00	3SE5 112-0LA00	3SE5 112-0LA00	3SE5 112-0LA00	3SE5 112-0LA00	3SE5 112-0LA00
							+ Actuator head	3SE5 000-0AC02	3SE5 000-0AD02	3SE5 000-0AE01	3SE5 000-0AE02	3SE5 000-0AF01	3SE5 000-0AF02	3SE5 000-0AR01
		M12 plug, 5-pole (2 NC, PE connected)	Complete unit	--			--	--	--	--	--	--		
		Basic switch	3SE5 114-0LA00-1AE1	3SE5 114-0LA00-1AE1			3SE5 114-0LA00-1AE1	3SE5 114-0LA00-1AE1	3SE5 114-0LA00-1AE1	3SE5 114-0LA00-1AE1	3SE5 114-0LA00-1AE1			
		+ Actuator head	3SE5 000-0AC02	3SE5 000-0AD02			3SE5 000-0AE01	3SE5 000-0AE02	3SE5 000-0AF01	3SE5 000-0AF02	3SE5 000-0AR01			

For ordering notes see page 7.

## Standard Position Switches Metal Enclosures, 40 mm

Switching points according to  
EN 50041, IP66/IP67

Complete unit and  
Module selection



Contact block		LED display	Connection	Twist actuators (switching right and/or left, adjustable)						Fork lever actuators						
				Twist levers		Length-adjustable twist levers		Rod actuators, 200 mm long		Fork lever actuators						
Contacts	Contact element			Metal levers		High-grade steel levers		Metal levers			Aluminum	Plastic	Metal levers			
				Plastic rollers	High-grade steel rollers	Plastic rollers	Plastic rollers	High-grade steel rollers	With latching holes, plastic rollers				Plastic rollers			
				$\leftrightarrow v_{max.} = 3\text{ m/s}$	$\leftrightarrow v_{max.} = 1,5\text{ m/s}$	$\leftrightarrow v_{max.} = 1,5\text{ m/s}$	$\leftrightarrow v_{max.} = 1,5\text{ m/s}$	$\leftrightarrow v_{max.} = 1,5\text{ m/s}$	$\leftrightarrow v_{max.} = 1,5\text{ m/s}$				$\leftrightarrow v_{max.} = 1,5\text{ m/s}$			
1 NO/ 1 NC	Slow action	without	1 x (M20 x 1.5)	Complete unit	3SE5 112-OBH01	3SE5 112-OBH02	--	3SE5 112-OBH50	--	3SE5 112-OBH60	--	--	--			
				Basic switch	3SE5 112-OBA00	3SE5 112-OBA00	3SE5 112-OBA00	3SE5 112-OBA00	3SE5 112-OBA00	3SE5 112-OBA00	3SE5 112-OBA00	3SE5 112-OBA00	3SE5 112-OBA00	3SE5 112-OBA00	3SE5 112-OBA00	
				+ Actuator head	3SE5 000-OAH00	3SE5 000-OAH00	3SE5 000-OAH00	3SE5 000-OAH00	3SE5 000-OAH00	3SE5 000-OAH00	3SE5 000-OAH00	3SE5 000-OAH00	3SE5 000-OAH00	3SE5 000-OAH00	3SE5 000-OAT10	
				+ Twist lever	3SE5 000-OAA01	3SE5 000-OAA02	3SE5 000-OAA11	3SE5 000-OAA50	3SE5 000-OAA51	3SE5 000-OAA60	3SE5 000-OAA80	3SE5 000-OAA82	3SE5 000-OAA82	3SE5 000-OAT01	3SE5 000-OAT01	
				M12 plug, 5-pole (PE connected)	--	--	--	--	--	--	--	--	--	--	--	
				Basic switch	3SE5 114-OBA00-1AC5	3SE5 114-OBA00-1AC5	3SE5 114-OBA00-1AC5	3SE5 114-OBA00-1AC5	3SE5 114-OBA00-1AC5	3SE5 114-OBA00-1AC5	3SE5 114-OBA00-1AC5	3SE5 114-OBA00-1AC5	3SE5 114-OBA00-1AC5	3SE5 114-OBA00-1AC5	3SE5 114-OBA00-1AC5	3SE5 114-OBA00-1AC5
				+ Actuator head	3SE5 000-OAH00	3SE5 000-OAH00	3SE5 000-OAH00	3SE5 000-OAH00	3SE5 000-OAH00	3SE5 000-OAH00	3SE5 000-OAH00	3SE5 000-OAH00	3SE5 000-OAH00	3SE5 000-OAH00	3SE5 000-OAT10	3SE5 000-OAT10
				+ Twist lever	3SE5 000-OAA01	3SE5 000-OAA02	3SE5 000-OAA11	3SE5 000-OAA50	3SE5 000-OAA51	3SE5 000-OAA60	3SE5 000-OAA80	3SE5 000-OAA82	3SE5 000-OAA82	3SE5 000-OAT01	3SE5 000-OAT01	
				Snap action	without	1 x (M20 x 1.5)	Complete unit	3SE5 112-0CH01	3SE5 112-0CH02	--	3SE5 112-0CH50	3SE5 112-0CH51	3SE5 112-0CH60	3SE5 112-0CH80	3SE5 112-0CH82	3SE5 112-0CT11
	Basic switch	3SE5 112-OCA00	3SE5 112-OCA00	3SE5 112-OCA00	3SE5 112-OCA00	3SE5 112-OCA00	3SE5 112-OCA00	3SE5 112-OCA00	3SE5 112-OCA00	3SE5 112-OCA00	3SE5 112-OCA00	3SE5 112-OCA00	3SE5 112-OCA00			
	+ Actuator head	3SE5 000-OAH00	3SE5 000-OAH00	3SE5 000-OAH00	3SE5 000-OAH00	3SE5 000-OAH00	3SE5 000-OAH00	3SE5 000-OAH00	3SE5 000-OAH00	3SE5 000-OAH00	3SE5 000-OAH00	3SE5 000-OAT10	3SE5 000-OAT10			
	+ Twist lever	3SE5 000-OAA01	3SE5 000-OAA02	3SE5 000-OAA11	3SE5 000-OAA50	3SE5 000-OAA51	3SE5 000-OAA60	3SE5 000-OAA80	3SE5 000-OAA82	3SE5 000-OAA82	3SE5 000-OAT01	3SE5 000-OAT01				
	M12 plug, 5-pole (PE connected)	--	--	--	--	--	--	--	--	--	--	--				
	Basic switch	3SE5 114-0CH01-1AC5	3SE5 114-0CH01-1AC5	3SE5 114-0CH01-1AC5	3SE5 114-0CH01-1AC5	3SE5 114-0CH01-1AC5	3SE5 114-0CH01-1AC5	3SE5 114-0CH01-1AC5	3SE5 114-0CH01-1AC5	3SE5 114-0CH01-1AC5	3SE5 114-0CH01-1AC5	3SE5 114-0CH01-1AC5	3SE5 114-0CH01-1AC5			
	+ Actuator head	3SE5 000-OAH00	3SE5 000-OAH00	3SE5 000-OAH00	3SE5 000-OAH00	3SE5 000-OAH00	3SE5 000-OAH00	3SE5 000-OAH00	3SE5 000-OAH00	3SE5 000-OAH00	3SE5 000-OAH00	3SE5 000-OAT10	3SE5 000-OAT10			
	+ Twist lever	3SE5 000-OAA01	3SE5 000-OAA02	3SE5 000-OAA11	3SE5 000-OAA50	3SE5 000-OAA51	3SE5 000-OAA60	3SE5 000-OAA80	3SE5 000-OAA82	3SE5 000-OAA82	3SE5 000-OAT01	3SE5 000-OAT01				
	2 LEDs, yellow / green, 24 V DC	M12 plug, 5-pole	M12 plug, 5-pole	Complete unit	3SE5 114-1CH01-1AF3	--	--	--	--	--	--	--	--			
	Basic switch	3SE5 114-1CA00-1AF3	3SE5 114-1CA00-1AF3	3SE5 114-1CA00-1AF3	3SE5 114-1CA00-1AF3	3SE5 114-1CA00-1AF3	3SE5 114-1CA00-1AF3	3SE5 114-1CA00-1AF3	3SE5 114-1CA00-1AF3	3SE5 114-1CA00-1AF3	3SE5 114-1CA00-1AF3	3SE5 114-1CA00-1AF3	3SE5 114-1CA00-1AF3			
+ Actuator head	3SE5 000-OAH00	3SE5 000-OAH00	3SE5 000-OAH00	3SE5 000-OAH00	3SE5 000-OAH00	3SE5 000-OAH00	3SE5 000-OAH00	3SE5 000-OAH00	3SE5 000-OAH00	3SE5 000-OAH00	3SE5 000-OAT10	3SE5 000-OAT10				
+ Twist lever	3SE5 000-OAA01	3SE5 000-OAA02	3SE5 000-OAA11	3SE5 000-OAA50	3SE5 000-OAA51	3SE5 000-OAA60	3SE5 000-OAA80	3SE5 000-OAA82	3SE5 000-OAA82	3SE5 000-OAT01	3SE5 000-OAT01					
1 NO/ 2 NC	Slow action	without	1 x M20 x 1.5)	Complete unit	3SE5 112-0KH01	--	--	--	--	--	--	--	--			
				Basic switch	3SE5 112-0KA00	3SE5 112-0KA00	3SE5 112-0KA00	3SE5 112-0KA00	3SE5 112-0KA00	3SE5 112-0KA00	3SE5 112-0KA00	3SE5 112-0KA00	3SE5 112-0KA00	3SE5 112-0KA00		
				+ Actuator head	3SE5 000-OAH00	3SE5 000-OAH00	3SE5 000-OAH00	3SE5 000-OAH00	3SE5 000-OAH00	3SE5 000-OAH00	3SE5 000-OAH00	3SE5 000-OAH00	3SE5 000-OAH00	3SE5 000-OAT10		
				+ Twist lever	3SE5 000-OAA01	3SE5 000-OAA02	3SE5 000-OAA11	3SE5 000-OAA50	3SE5 000-OAA51	3SE5 000-OAA60	3SE5 000-OAA80	3SE5 000-OAA82	3SE5 000-OAA82	3SE5 000-OAT01		
				M12 plug, 5-pole (2 NC, PE connected)	--	--	--	--	--	--	--	--	--	--		
				Basic switch	3SE5 114-0KA00-1AE1	3SE5 114-0KA00-1AE1	3SE5 114-0KA00-1AE1	3SE5 114-0KA00-1AE1	3SE5 114-0KA00-1AE1	3SE5 114-0KA00-1AE1	3SE5 114-0KA00-1AE1	3SE5 114-0KA00-1AE1	3SE5 114-0KA00-1AE1	3SE5 114-0KA00-1AE1	3SE5 114-0KA00-1AE1	
				+ Actuator head	3SE5 000-OAH00	3SE5 000-OAH00	3SE5 000-OAH00	3SE5 000-OAH00	3SE5 000-OAH00	3SE5 000-OAH00	3SE5 000-OAH00	3SE5 000-OAH00	3SE5 000-OAH00	3SE5 000-OAH00	3SE5 000-OAT10	
				+ Twist lever	3SE5 000-OAA01	3SE5 000-OAA02	3SE5 000-OAA11	3SE5 000-OAA50	3SE5 000-OAA51	3SE5 000-OAA60	3SE5 000-OAA80	3SE5 000-OAA82	3SE5 000-OAA82	3SE5 000-OAT01	3SE5 000-OAT01	
				Snap action	without	1 x (M20 x 1.5)	Complete unit	3SE5 112-0LH01	--	--	3SE5 112-0LH50	--	3SE5 112-0LH60	--	--	--
	Basic switch	3SE5 112-0LA00	3SE5 112-0LA00	3SE5 112-0LA00	3SE5 112-0LA00	3SE5 112-0LA00	3SE5 112-0LA00	3SE5 112-0LA00	3SE5 112-0LA00	3SE5 112-0LA00	3SE5 112-0LA00	3SE5 112-0LA00	3SE5 112-0LA00			
	+ Actuator head	3SE5 000-OAH00	3SE5 000-OAH00	3SE5 000-OAH00	3SE5 000-OAH00	3SE5 000-OAH00	3SE5 000-OAH00	3SE5 000-OAH00	3SE5 000-OAH00	3SE5 000-OAH00	3SE5 000-OAH00	3SE5 000-OAT10				
	+ Twist lever	3SE5 000-OAA01	3SE5 000-OAA02	3SE5 000-OAA11	3SE5 000-OAA50	3SE5 000-OAA51	3SE5 000-OAA60	3SE5 000-OAA80	3SE5 000-OAA82	3SE5 000-OAA82	3SE5 000-OAT01					
	M12 plug, 5-pole (2 NC, PE connected)	--	--	--	--	--	--	--	--	--	--					
	Basic switch	3SE5 114-0LA00-1AE1	3SE5 114-0LA00-1AE1	3SE5 114-0LA00-1AE1	3SE5 114-0LA00-1AE1	3SE5 114-0LA00-1AE1	3SE5 114-0LA00-1AE1	3SE5 114-0LA00-1AE1	3SE5 114-0LA00-1AE1	3SE5 114-0LA00-1AE1	3SE5 114-0LA00-1AE1	3SE5 114-0LA00-1AE1				
	+ Actuator head	3SE5 000-OAH00	3SE5 000-OAH00	3SE5 000-OAH00	3SE5 000-OAH00	3SE5 000-OAH00	3SE5 000-OAH00	3SE5 000-OAH00	3SE5 000-OAH00	3SE5 000-OAH00	3SE5 000-OAH00	3SE5 000-OAT10				
	+ Twist lever	3SE5 000-OAA01	3SE5 000-OAA02	3SE5 000-OAA11	3SE5 000-OAA50	3SE5 000-OAA51	3SE5 000-OAA60	3SE5 000-OAA80	3SE5 000-OAA82	3SE5 000-OAA82	3SE5 000-OAT01					

For ordering notes see page 7.

# Standard Position Switches Metal Enclosures, 56mm

Switching points according to  
EN 50041, IP66/IP67

Complete unit and  
Module selection



				Rounded plungers	Roller plungers	Roller levers	Angular roller levers		Spring rod actuators				
				High-grade steel plungers, with overtravel ↓ v <sub>max.</sub> = 1 m/s	High-grade steel rollers ↔ v <sub>max.</sub> = 1 m/s	Metal levers ← v <sub>max.</sub> = 1 m/s	Metal levers		Plastic plungers, total length 143 mm v <sub>max.</sub> = 1 m/s				
						Plastic rollers ← v <sub>max.</sub> = 1 m/s	High-grade steel rollers ← v <sub>max.</sub> = 1 m/s	Plastic rollers ↑ v <sub>max.</sub> = 1 m/s	High-grade steel rollers ↑ v <sub>max.</sub> = 1 m/s				
Contact block	LED display	Connection											
Contacts	Contact element												
1 NO/ 1 NC	Slow action	without	3 x (M20 x 1.5)	Complete unit	3SE5 122-0BC02	3SE5 122-0BD02	3SE5 122-0BE01	--	3SE5 122-0BF01	--	--		
				Basic switch	3SE5 122-0BA00	3SE5 122-0BA00	3SE5 122-0BA00	3SE5 122-0BA00	3SE5 122-0BA00	3SE5 122-0BA00	--		
				+ Actuator head	3SE5 000-0AC02	3SE5 000-0AD02	3SE5 000-0AE01	3SE5 000-0AE02	3SE5 000-0AF01	3SE5 000-0AF02	--		
	Snap action	without	3 x (M20 x 1.5)	Complete unit	3SE5 122-0CC02	3SE5 122-0CD02	3SE5 122-0CE01	3SE5 122-0CE02	3SE5 122-0CF01	--	3SE5 122-0CR01		
				Basic switch	3SE5 122-0CA00	3SE5 122-0CA00	3SE5 122-0CA00	3SE5 122-0CA00	3SE5 122-0CA00	3SE5 122-0CA00	3SE5 122-0CA00	3SE5 122-0CA00	
				+ Actuator head	3SE5 000-0AC02	3SE5 000-0AD02	3SE5 000-0AE01	3SE5 000-0AE02	3SE5 000-0AF01	3SE5 000-0AF02	3SE5 000-0AR01		
	1 NO/ 2 NC	Slow action	without	3 x (M20 x 1.5)	Complete unit	3SE5 122-0KC02	3SE5 122-0KD02	3SE5 122-0KE01	--	--	--	--	
					Basic switch	3SE5 122-0KA00	3SE5 122-0KA00	3SE5 122-0KA00	3SE5 122-0KA00	3SE5 122-0KA00	3SE5 122-0KA00	3SE5 122-0KA00	--
					+ Actuator head	3SE5 000-0AC02	3SE5 000-0AD02	3SE5 000-0AE01	3SE5 000-0AE02	3SE5 000-0AF01	3SE5 000-0AF02	--	
2 LEDs, yellow / green, 24 V DC		3 x (M20 x 1.5)	Complete unit	--	--	--	--	--	--	--	--		
			Basic switch	3SE5 122-1KA00	3SE5 122-1KA00	3SE5 122-1KA00	3SE5 122-1KA00	3SE5 122-1KA00	3SE5 122-1KA00	3SE5 122-1KA00	--		
			+ Actuator head	3SE5 000-0AC02	3SE5 000-0AD02	3SE5 000-0AE01	3SE5 000-0AE02	3SE5 000-0AF01	3SE5 000-0AF02	--			
Snap action		without	3 x (M20 x 1.5)	Complete unit	3SE5 122-0LC02	3SE5 122-0LD02	3SE5 122-0LE01	--	--	--	--		
				Basic switch	3SE5 122-0LA00	3SE5 122-0LA00	3SE5 122-0LA00	3SE5 122-0LA00	3SE5 122-0LA00	3SE5 122-0LA00	3SE5 122-0LA00	3SE5 122-0LA00	
				+ Actuator head	3SE5 000-0AC02	3SE5 000-0AD02	3SE5 000-0AE01	3SE5 000-0AE02	3SE5 000-0AF01	3SE5 000-0AF02	3SE5 000-0AR01		
2 LEDs, yellow / green, 24 V DC	3 x (M20 x 1.5)	Complete unit	--	--	--	--	--	--	--	--			
		Basic switch	3SE5 122-1LA00	3SE5 122-1LA00	3SE5 122-1LA00	3SE5 122-1LA00	3SE5 122-1LA00	3SE5 122-1LA00	3SE5 122-1LA00	3SE5 122-1LA00			
		+ Actuator head	3SE5 000-0AC02	3SE5 000-0AD02	3SE5 000-0AE01	3SE5 000- AE02	3SE5 000-0AF01	3SE5 000-0AF02	3SE5 000-0AR01				

For ordering notes see page 7.

Standard Position Switches  
Metal Enclosures, 56 mm  
Switching points according to  
EN 50041, IP66/IP67

Complete unit and  
Module selection



				Twist actuators (switching right and/or left, adjustable)						Fork lever actuators				
				Twist levers			Length-adjustable twist levers			Rod actuators, 200 mm long				
Contact block		LED display	Connection	Metal levers		High-grade steel levers		Metal levers			Aluminum	Plastic	Metal levers	
Contacts	Contact element			Plastic rollers	High-grade steel rollers	Plastic rollers	Plastic rollers	High-grade steel rollers	With latching holes, plastic rollers			Plastic rollers		
				$\leftrightarrow v_{max.} = 1,5 \text{ m/s}$	$\leftrightarrow v_{max.} = 1,5 \text{ m/s}$	$\leftrightarrow v_{max.} = 1,5 \text{ m/s}$	$\leftrightarrow v_{max.} = 1,5 \text{ m/s}$	$\leftrightarrow v_{max.} = 1,5 \text{ m/s}$	$\leftrightarrow v_{max.} = 1,5 \text{ m/s}$	$\leftrightarrow v_{max.} = 1 \text{ m/s}$	$\leftrightarrow v_{max.} = 1 \text{ m/s}$	$\leftrightarrow v_{max.} = 1,5 \text{ m/s}$		
1 NO/ 1 NC	Slow action	without	3 x (M20 x 1.5)	Complete unit	3SE5 122-0BH01	--	--	3SE5 122-0BH50	--	3SE5 122-0BH60	--	--	--	
				Basic switch	3SE5 122-0BA00	3SE5 122-0BA00	3SE5 122-0BA00	3SE5 122-0BA00	3SE5 122-0BA00	3SE5 122-0BA00	3SE5 122-0BA00	3SE5 122-0BA00	3SE5 122-0BA00	3SE5 122-0BA00
				+ Actuator head	3SE5 000-0AH00	3SE5 000-0AH00	3SE5 000-0AH00	3SE5 000-0AH00	3SE5 000-0AH00	3SE5 000-0AH00	3SE5 000-0AH00	3SE5 000-0AH00	3SE5 000-0AH00	3SE5 000-0AT10
				+ Twist lever	3SE5 000-0AA01	3SE5 000-0AA02	3SE5 000-0AA11	3SE5 000-0AA50	3SE5 000-0AA51	3SE5 000-0AA60	3SE5 000-0AA80	3SE5 000-0AA82	3SE5 000-0AT01	
				Complete unit	3SE5 122-0CH01	3SE5 122-0CH02	--	3SE5 122-0CH50	--	3SE5 122-0CH60	3SE5 122-0CH80	3SE5 122-0CH82	3SE5 122-0CT11	
				Basic switch	3SE5 122-0CA00	3SE5 122-0CA00	3SE5 122-0CA00	3SE5 122-0CA00	3SE5 122-0CA00	3SE5 122-0CA00	3SE5 122-0CA00	3SE5 122-0CA00	3SE5 122-0CA00	
	+ Actuator head	3SE5 000-0AH00	3SE5 000-0AH00	3SE5 000-0AH00	3SE5 000-0AH00	3SE5 000-0AH00	3SE5 000-0AH00	3SE5 000-0AH00	3SE5 000-0AH00	3SE5 000-0AT10				
	+ Twist lever	3SE5 000-0AA01	3SE5 000-0AA02	3SE5 000-0AA11	3SE5 000-0AA50	3SE5 000-0AA51	3SE5 000-0AA60	3SE5 000-0AA80	3SE5 000-0AA82	3SE5 000-0AT01				
	1 NO/ 2 NC	Slow action	without	3 x (M20 x 1.5)	Complete unit	3SE5 122-0KH01	--	--	--	--	--	--	--	--
					Basic switch	3SE5 122-0KA00	3SE5 122-0KA00	3SE5 122-0KA00	3SE5 122-0KA00	3SE5 122-0KA00	3SE5 122-0KA00	3SE5 122-0KA00	3SE5 122-0KA00	3SE5 122-0KA00
					+ Actuator head	3SE5 000-0AH00	3SE5 000-0AH00	3SE5 000-0AH00	3SE5 000-0AH00	3SE5 000-0AH00	3SE5 000-0AH00	3SE5 000-0AH00	3SE5 000-0AH00	3SE5 000-0AT10
					+ Twist lever	3SE5 000-0AA01	3SE5 000-0AA02	3SE5 000-0AA11	3SE5 000-0AA50	3SE5 000-0AA51	3SE5 000-0AA60	3SE5 000-0AA80	3SE5 000-0AA82	3SE5 000-0AT01
Complete unit					--	--	--	--	--	--	--	--	--	
Basic switch					3SE5 122-1KA00	3SE5 122-1KA00	3SE5 122-1KA00	3SE5 122-1KA00	3SE5 122-1KA00	3SE5 122-1KA00	3SE5 122-1KA00	3SE5 122-1KA00	3SE5 122-1KA00	
+ Actuator head		3SE5 000-0AH00	3SE5 000-0AH00	3SE5 000-0AH00	3SE5 000-0AH00	3SE5 000-0AH00	3SE5 000-0AH00	3SE5 000-0AH00	3SE5 000-0AH00	3SE5 000-0AT10				
+ Twist lever		3SE5 000-0AA01	3SE5 000-0AA02	3SE5 000-0AA11	3SE5 000-0AA50	3SE5 000-0AA51	3SE5 000-0AA60	3SE5 000-0AA80	3SE5 000-0AA82	3SE5 000-0AT01				
Snap action		without	3 x (M20 x 1.5)	Complete unit	3SE5 122-0LH01	3SE5 122-0LH02	--	3SE5 122-0LH50	--	3SE5 122-0LH60	--	--	--	
				Basic switch	3SE5 122-0LA00	3SE5 122-0LA00	3SE5 122-0LA00	3SE5 122-0LA00	3SE5 122-0LA00	3SE5 122-0LA00	3SE5 122-0LA00	3SE5 122-0LA00	3SE5 122-0LA00	
				+ Actuator head	3SE5 000-0AH00	3SE5 000-0AH00	3SE5 000-0AH00	3SE5 000-0AH00	3SE5 000-0AH00	3SE5 000-0AH00	3SE5 000-0AH00	3SE5 000-0AH00	3SE5 000-0AT10	
				+ Twist lever	3SE5 000-0AA01	3SE5 000-0AA02	3SE5 000-0AA11	3SE5 000-0AA50	3SE5 000-0AA51	3SE5 000-0AA60	3SE5 000-0AA80	3SE5 000-0AA82	3SE5 000-0AT01	
	Complete unit			--	--	--	--	--	--	--	--	--		
	Basic switch			3SE5 122-1LA00	3SE5 122-1LA00	3SE5 122-1LA00	3SE5 122-1LA00	3SE5 122-1LA00	3SE5 122-1LA00	3SE5 122-1LA00	3SE5 122-1LA00	3SE5 122-1LA00		
+ Actuator head	3SE5 000-0AH00	3SE5 000-0AH00	3SE5 000-0AH00	3SE5 000-0AH00	3SE5 000-0AH00	3SE5 000-0AH00	3SE5 000-0AH00	3SE5 000-0AH00	3SE5 000-0AT10					
+ Twist lever	3SE5 000-0AA01	3SE5 000-0AA02	3SE5 000-0AA11	3SE5 000-0AA50	3SE5 000-0AA51	3SE5 000-0AA60	3SE5 000-0AA80	3SE5 000-0AA82	3SE5 000-0AT01					
Snap action	2 LEDs, yellow / green, 24 V DC	3 x (M20 x 1.5)	Complete unit	--	--	--	--	--	--	--	--	--		
			Basic switch	3SE5 122-1LA00	3SE5 122-1LA00	3SE5 122-1LA00	3SE5 122-1LA00	3SE5 122-1LA00	3SE5 122-1LA00	3SE5 122-1LA00	3SE5 122-1LA00	3SE5 122-1LA00		
			+ Actuator head	3SE5 000-0AH00	3SE5 000-0AH00	3SE5 000-0AH00	3SE5 000-0AH00	3SE5 000-0AH00	3SE5 000-0AH00	3SE5 000-0AH00	3SE5 000-0AH00	3SE5 000-0AT10		
			+ Twist lever	3SE5 000-0AA01	3SE5 000-0AA02	3SE5 000-0AA11	3SE5 000-0AA50	3SE5 000-0AA51	3SE5 000-0AA60	3SE5 000-0AA80	3SE5 000-0AA82	3SE5 000-0AT01		
			Complete unit	--	--	--	--	--	--	--	--	--		
			Basic switch	3SE5 122-1LA00	3SE5 122-1LA00	3SE5 122-1LA00	3SE5 122-1LA00	3SE5 122-1LA00	3SE5 122-1LA00	3SE5 122-1LA00	3SE5 122-1LA00	3SE5 122-1LA00		
+ Actuator head	3SE5 000-0AH00	3SE5 000-0AH00	3SE5 000-0AH00	3SE5 000-0AH00	3SE5 000-0AH00	3SE5 000-0AH00	3SE5 000-0AH00	3SE5 000-0AH00	3SE5 000-0AT10					
+ Twist lever	3SE5 000-0AA01	3SE5 000-0AA02	3SE5 000-0AA11	3SE5 000-0AA50	3SE5 000-0AA51	3SE5 000-0AA60	3SE5 000-0AA80	3SE5 000-0AA82	3SE5 000-0AT01					

For ordering notes see page 7.





# Convincing Performance: SIRIUS Standard Position Switches

## SIRIUS open-type standard position switches: with even greater compactness, IP10, IP20

Their compact design makes them particularly suitable for use in confined conditions.

Our open-type position switches are equipped as standard with three contacts.

The fixing dimensions are according to EN 50047

3SE5 position switches, open-type			
Version	Contacts	Contact element	Order No.
Plastic enclosures, 30 mm wide			
Rounded plungers, teflon Ø 6 mm, 6 mm travel	1 NO/1 NC	Slow action 	3SE5 250-0BC05
		Snap action 	3SE5 250-0CC05
	1 NO/2 NC	Slow action 	3SE5 250-0KC05
		Snap action 	3SE5 250-0LC05





# Maximizing Safety at Field Level: SIRIUS Safety Position Switches

You can totally rely on SIRIUS detecting devices. Besides a wide range of reliable devices for standard applications, our portfolio also includes a whole family of detecting devices which are designed for use in safety circuits. These devices can be used in detection applications up to EN 954-1 Category 4 and SIL3 according to IEC 62061. Different switch types are available to handle a variety of applications.

Tamper-proof **position switches with separate actuator** are a good choice for checking the position of protective doors. **Position switches with solenoid interlocking** are a reliable and safe solution when interlocking is needed to eliminate hazards, for example within the working radius of a robotics system. **Hinge switches** with positive locking between the switch and the door hinge offer excellent tamper protection in pivoting door and cover applications. In other words: You get maximum safety and flexibility when you design SIRIUS detecting devices into your solutions.

Demand for safety position switches continues to increase, and customers expect that the switches will offer even better functionality. Because the switches play such an important role, we have developed a new generation of products which offers a whole range of additional functions.

## New features

- **Optional LED displays** are available for all enclosures to facilitate user-friendly on-site diagnosis.
- The entire **ASIsafe electronics are now integrated into the enclosure** – ASIsafe now does not take up any extra space.

Safety position switches with solenoid interlocking now offer additional functionality:

- **High locking forces** up to 2600 N (metal version) and 1300 N (plastic version)
- **A number of additional release mechanisms** to handle any application.
- Direct connection to the ASi network with a **very low current load** of  $\leq 170$  mA
- **2 x 3 contacts** as standard





# SIRIUS Position Switches with Separate Actuator: Proven and Safe

SIRIUS position switches with separate actuator are the ideal choice if you need to be absolutely sure that the safety mechanism on protective doors cannot be deactivated. Multiple mechanical coding virtually eliminates any possibility of tampering. The separate actuator is mounted directly on the protective door. When the door is closed, the actuator moves into the

opening on the switch. When the door is opened, the actuator is removed from the switch and the NC contacts open. The circuit is broken – safely and reliably. Full actuator rotation in four 90° increments and approach from the top give you the flexibility you need for your application.

3SE5 position switches with separate actuator			
Contacts (slow-action contact element)	Version	LED display	Order No.
Plastic enclosures according to EN 50047 (31 mm wide), 5 directions of approach			
1 NO/1 NC	1 x (M20 x 1.5)	without	3SE5 232-0RV40
		yellow + green, 24 V DC	3SE5 232-1RV40
		yellow + green, 115 V - 230 V AC	3SE5 232-3RV40
	M12 plug, 5-pole (1 NO/1 NC connected); max. 24 V DC, 4 A	yellow + green, 24 V DC	3SE5 234-1RV40-1AF3
	M12 plug, 4-pole (1 NO/1 NC connected); max. 250 V AC, 4 A	without	3SE5 234-0RV40-1AC4
1 NO/2 NC	1 x (M20 x 1.5)	without	3SE5 232-0QV40
	M12 plug, 4-pole (2 NC connected); max. 250 V AC, 4 A	without	3SE5 234-0QV40-1AE0
Plastic enclosures (50 mm wide), 5 directions of approach			
1 NO/2 NC	2 x (M20 x 1.5)	without	3SE5 242-0QV40
		yellow + green, 24 V DC	3SE5 242-1QV40
		yellow + green, 115 V - 230 V AC	3SE5 242-3QV40
Metal enclosures according to EN 50041 (40 mm wide), 5 directions of approach			
1 NO/1 NC	M12 plug, plastic, 5-pole, (1 NO/1 NC connected); max. 24 V DC, 4 A	yellow + green, 24 V DC	3SE5 114-1RV10-1AF3
	M12 plug, plastic, 5-pole, (1 NO/1 NC, PE connected); max. 24 V AC/DC, 4 A	without	3SE5 114-0RV10-1AC5
	Plug 6 + PE according to EN 43651, plastic (1 NO/1 NC and PE connected); max. 24 V DC, 6 A	yellow + green, 24 V DC	3SE5 115-1RV10-1AF2
	Plug 6 + PE according to EN 43651, plastic (1 NO/1 NC and PE connected); max. 250 V AC, 6 A	without	3SE5 115-0RV10-1AD1
1 NO/2 NC	1 x (M20 x 1.5)	without	3SE5 112-0QV10
		yellow + green, 24 V DC	3SE5 112-1QV10
		yellow + green, 115 V - 230 V AC	3SE5 112-3QV10
2 NC	M12 plug, plastic, 5-pole, (2 NC, PE connected); max. 24 V AC/DC, 4 A	without	3SE5 114-0QV10-1AE1
Metal enclosures (56 mm wide), 5 directions of approach			
1 NO/2 NC	3 x (M20 x 1.5)	without	3SE5 122-0QV10
		yellow + green, 24 V DC	3SE5 122-1QV10
		yellow + green, 115 V - 230 V AC	3SE5 122-3QV10

### Actuators for 3SE5/3SF1 position switches with separate actuator

	Standard actuators	3SE5 000-0AV01
	Actuators with vertical fixing	3SE5 000-0AV02
	Actuators with transverse fixing	3SE5 000-0AV03
	Radius actuators, left	3SE5 000-0AV04
	Radius actuators, right	3SE5 000-0AV06
	Universal radius actuators	3SE5 000-0AV05

The position switches with separate actuator can only be operated with the matching coded actuator. Simple overruling by hand or auxiliary devices is impossible. The actuators are not included in the scope of supply of the switch and must be ordered separately.



# SIRIUS Position Switches with Solenoid Interlocking: Clever and Reliable

When protective doors have to remain closed while a machine is being shut down, for example to prevent access to the working radius of a robotic system, SIRIUS position switches with separate actuator and additional electromagnetic tumbler are the best solution. An integrated auxiliary magnet keeps the door locked until a specific signal has been received. Not even a force of 2600 N is sufficient to remove the actuator. A safety mechanism to prevent unwanted closing ensures that the NC contacts of the magnet never close even when the door is open. The switch can be released manually using an auxiliary release mechanism if, for example, access is required following a power failure or during installation. Some of the outstanding standard features include an integrated solenoid interlocking with 24 V, 115 V or 230 V coil voltage, 6 switching contacts and separate position sensing for the magnet and the protective door. Optical status monitoring is also available.

## New features

- **Higher locking forces** (2600 N on the metal version, 1300 N on the plastic versions) guarantee enhanced safety even in harsh industrial environments.
- **2 x 3 contacts are included as standard.** Two NC contacts and one NO contact are provided for magnet and actuator monitoring.
- **The new, innovative ASIsafe solution** with integrated module, which has been designed with safety in mind, greatly reduces the load on the data line. The maximum current consumption possible of the magnet is 170 mA.
- **A number of additional release mechanisms** to handle any application: auxiliary release mechanism, lock release, escape release and emergency release
- **The actuator heads** can be rotated in 4 x 90° increments; 5 directions of approach (4 x lateral + 1 x front)



# Position Switches with Solenoid Interlocking

## Release Variants

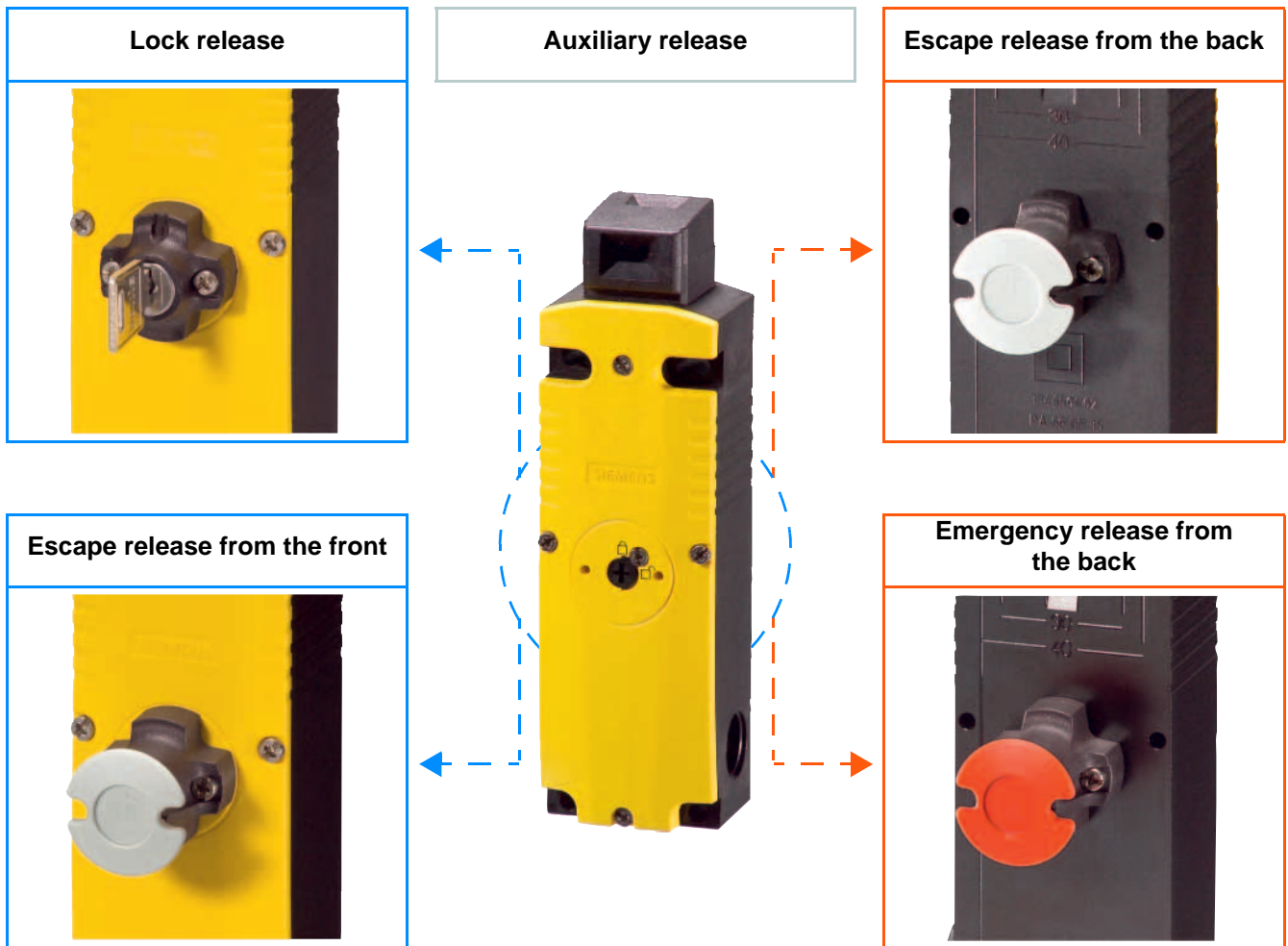



- Personnel working inside the hazard zone can use the **escape release** feature to manually release the tumbler without tools so that they can exit the hazard area. An intentional act (in this case pulling the gray actuator) is required to release the locking mechanism and restore the normal operating state. (Source: GS-ET 19)

- **Emergency release** enables someone outside of the hazard zone to manually release the tumbler without tools in an emergency situation. Releasing the lock and restoring the normal operating status must require effort which is comparable to repair activity, in this case removal of the red actuator and resetting the mechanical lock.

## 3SE5 position switches with solenoid interlocking, complete units

Version	Release	Magnet voltage	LED display	Plastic enclosure	Metal enclosure
				Order No.	Order No.
Spring-actuated lock (closed-circuit principle) Actuator contacts 1 NO/2 NC Magnet contacts 1 NO/2 NC	 Auxiliary release	24 V DC	--	3SE5 322-0SD21	3SE5 312-0SD11
			yellow / green	3SE5 322-1SD21	3SE5 312-1SD11
		115 V AC	--	3SE5 322-0SD22	3SE5 312-0SD12
			yellow / green	3SE5 322-2SD22	3SE5 312-2SD12
		230 V AC	--	3SE5 322-0SD23	3SE5 312-0SD13
			yellow / green	3SE5 322-3SD23	3SE5 312-3SD13
	 Auxiliary release with lock	24 V DC	--	3SE5 322-0SE21	3SE5 312-0SE11
			yellow / green	3SE5 322-1SE21	3SE5 312-1SE11
		115 V AC	--	3SE5 322-0SE22	3SE5 312-0SE12
			yellow / green	3SE5 322-2SE22	3SE5 312-2SE12
		230 V AC	--	3SE5 322-0SE23	3SE5 312-0SE13
			yellow / green	3SE5 322-3SE23	3SE5 312-3SE13
	 Escape release from the front	24 V DC	--	3SE5 322-0SF21	3SE5 312-0SF11
			yellow / green	3SE5 322-1SF21	3SE5 312-1SF11
		115 V AC	--	3SE5 322-0SF22	3SE5 312-0SF12
			yellow / green	3SE5 322-2SF22	3SE5 312-2SF12
		230 V AC	--	3SE5 322-0SF23	3SE5 312-0SF13
			yellow / green	3SE5 322-3SF23	3SE5 312-3SF13
	 Escape release from the back and auxiliary release from the front	24 V DC	--	3SE5 322-0SG21	3SE5 312-0SG11
			yellow / green	3SE5 322-1SG21	3SE5 312-1SG11
		115 V AC	--	3SE5 322-0SG22	3SE5 312-0SG12
			yellow / green	3SE5 322-2SG22	3SE5 312-2SG12
		230 V AC	--	3SE5 322-0SG23	3SE5 312-0SG13
			yellow / green	3SE5 322-3SG23	3SE5 312-3SG13
 Emergency release from the back and auxiliary release from the front	24 V DC	--	3SE5 322-0SJ21	3SE5 312-0SJ11	
		yellow / green	3SE5 322-1SJ21	3SE5 312-1SJ11	
	115 V AC	--	3SE5 322-0SJ22	3SE5 312-0SJ12	
		yellow / green	3SE5 322-2SJ22	3SE5 312-2SJ12	
	230 V AC	--	3SE5 322-0SJ23	3SE5 312-0SJ13	
		yellow / green	3SE5 322-3SJ23	3SE5 312-3SJ13	
Magnetic field lock (open-circuit principle) Actuator contacts 1 NO/2 NC Magnet contacts 1 NO/2 NC		24 V DC	--	3SE5 322-0SB21	3SE5 312-0SB11
			yellow / green	3SE5 322-1SB21	3SE5 312-1SB11
		115 V AC	--	3SE5 322-0SB22	3SE5 312-0SB12
			yellow / green	3SE5 322-2SB22	3SE5 312-2SB12
		230 V AC	--	3SE5 322-0SB23	3SE5 312-0SB13
			yellow / green	3SE5 322-3SB23	3SE5 312-3SB13

### Actuators for 3SE5/3SF1 position switches with solenoid interlocking

	Standard actuators	3SE5 000-0AV01
	Actuators with vertical fixing	3SE5 000-0AV02
	Actuators with transverse fixing	3SE5 000-0AV03
	Radius actuators, left	3SE5 000-0AV04
	Radius actuators, right	3SE5 000-0AV06
	Universal radius actuators	3SE5 000-0AV05

The position switches with solenoid interlocking can only be operated with the matching coded actuator. Simple overruling by hand or auxiliary devices is impossible. The actuators are not included in the scope of supply of the switch and must be ordered separately.

# SIRIUS Hinge Switches: Tamper-Proof

Our offering of hinge switches rounds off the range of position switches for monitoring hinged doors and flaps. With their fixed, positive connection between the switch and the door hinge directly at the pivoting point of the protective device, these mechanical switches offer excellent protection from overruling and tampering. And the same time hinge switches in standard enclosures according to EN 50047 and EN 50041 have a very small operating angle of just 5°. Simultaneous shutdown and signaling is provided in addition by the 1 NO/1 NC snap-action contacts. SIRIUS hinge switches are available as complete units only.



## 3SE5 hinge switches, complete units

		 Hollow shaft $\varnothing_{\text{int.}} = 8 \text{ mm}$ , $\varnothing_{\text{ext.}} = 12 \text{ mm}$		 Solid shaft $\varnothing = 10 \text{ mm}$		
		Operating angle 5° ↻	Operating angle 15° ↻	Operating angle 5° ↻	Operating angle 15° ↻	
		Contacts	Contact element			
Plastic enclosures according to EN 50047 (31 mm wide), mounting on hinges						
	1 NO/ 1 NC	Snap action	--	3SE5 232-0HU21	--	3SE5 232-0HU22
	1 NO/ 2 NC	Snap action	3SE5 232-0LU11	3SE5 232-0LU21	3SE5 232-0LU12	3SE5 232-0LU22
Plastic enclosures according to EN 50041 (40 mm wide), mounting on hinges						
	1 NO/ 1 NC	Snap action	3SE5 112-0LU11	3SE5 112-0LU21	3SE5 112-0LU12	3SE5 112-0LU22



# AS-Interface Connections: Total Flexibility



If you want to deploy networking solutions in your system, SIRIUS detecting devices are the ideal choice. All of the components can be used in AS-Interface system environments. This is because they comply with IEC 62026-2 and are fully compatible with familiar AS-Interface components such as master, slaves, power supply, etc. Hence they can be used together on the yellow AS-Interface line. We supply all of the components you need to set up a safe AS-Interface network.

## New features

Our new generation of switches enables easy and fast connection to the AS-i network because:

- **The complete range of 3SE5 position switches is available with integrated ASIsafe electronics:**
  - Standard position switches
  - Position switches with separate actuator
  - Position switches with tumbler
  - Hinge switches
- **Connection to the AS-Interface system** is by means of an **M12 plug**.
- **Direct integration of the safety position switches with tumbler in the AS-i network** results in a very low data line load. The maximum current carrying capacity is at 170 mA.



## 3SF1 Standard Position Switches with Integrated ASIsafe Electronics

Module selection

### Plastic enclosures



Enclosure	Contacts	Contact element	Connection		Rounded plungers		Roller plungers		Roller levers		Angular roller levers		Spring rod actuators		
					↓ $v_{max.} = 1 \text{ m/s}$ ↻	↓ $v_{max.} = 1 \text{ m/s}$ ↻	← $v_{max.} = 1 \text{ m/s}$ ↻	← $v_{max.} = 1 \text{ m/s}$ ↻	↑ $v_{max.} = 1 \text{ m/s}$ ↻	← $v_{max.} = 1 \text{ m/s}$ ↻	$v_{max.} = 1 \text{ m/s}$				
31 mm wide acc. to EN 50047	2 NC	Slow action	M12 plug, 4-pole; channel 1 on NC contact, channel 2 on NC contact	Basic switch	3SF1 234-1KC05-1BA1	3SF1 234-1KC05-1BA1	3SF1 234-1KC05-1BA1	3SF1 234-1KC05-1BA1	3SF1 234-1KC05-1BA1	3SF1 234-1KC05-1BA1	3SF1 234-1KC05-1BA1	3SF1 234-1KC05-1BA1	--		
				+ Actuator head	--	3SE5 000-0AD03	3SE5 000-0AE10	3SE5 000-0AE12	3SE5 000-0AF10	3SE5 000-0AF12	--				
		Snap action		Basic switch	3SF1 234-1LC05-1BA1	3SF1 234-1LC05-1BA1	3SF1 234-1LC05-1BA1	3SF1 234-1LC05-1BA1	3SF1 234-1LC05-1BA1	3SF1 234-1LC05-1BA1	3SF1 234-1LC05-1BA1	3SF1 234-1LC05-1BA1	3SF1 234-1LC05-1BA1	3SF1 234-1LC05-1BA1	3SF1 234-1LC05-1BA1
				+ Actuator head	--	3SE5 000-0AD03	3SE5 000-0AE10	3SE5 000-0AE12	3SE5 000-0AF10	3SE5 000-0AF12	3SE5 000-0AR01				
50 mm wide	2 NC	Slow action	M12 plug, 4-pole; channel 1 on NC contact, channel 2 on M12 socket right	Basic switch	3SF1 244-1KC05-1BA2	3SF1 244-1KC05-1BA2	3SF1 244-1KC05-1BA2	3SF1 244-1KC05-1BA2	3SF1 244-1KC05-1BA2	3SF1 244-1KC05-1BA2	3SF1 244-1KC05-1BA2	3SF1 244-1KC05-1BA2	--		
				+ Actuator head	--	3SE5 000-0AD03	3SE5 000-0AE10	3SE5 000-0AE12	3SE5 000-0AF10	3SE5 000-0AF12	--				
		Snap action		Basic switch	3SF1 244-1LC05-1BA2	3SF1 244-1LC05-1BA2	3SF1 244-1LC05-1BA2	3SF1 244-1LC05-1BA2	3SF1 244-1LC05-1BA2	3SF1 244-1LC05-1BA2	3SF1 244-1LC05-1BA2	3SF1 244-1LC05-1BA2	3SF1 244-1LC05-1BA2	3SF1 244-1LC05-1BA2	
				+ Actuator head	--	3SE5 000-0AD03	3SE5 000-0AE10	3SE5 000-0AE12	3SE5 000-0AF10	3SE5 000-0AF12	3SE5 000-0AR01				

### Metal enclosures



Enclosure	Contacts	Contact element	Connection		Rounded plungers		Roller plungers		Roller levers		Angular roller levers		Spring rod actuators	
					↓ $v_{max.} = 1 \text{ m/s}$ ↻	↔ $v_{max.} = 1 \text{ m/s}$ ↻	← $v_{max.} = 1 \text{ m/s}$ ↻	← $v_{max.} = 1 \text{ m/s}$ ↻	↑ $v_{max.} = 2.5 \text{ m/s}$ ↻	↑ $v_{max.} = 2.5 \text{ m/s}$ ↻	$v_{max.} = 1 \text{ m/s}$			
40 mm wide acc. to EN 50041	2 NC	Slow action	M12 plug, 4-pole; channel 1 on NC contact, channel 2 on NC contact	Basic switch	3SF1 114-1KA00-1BA1	3SF1 114-1KA00-1BA1	3SF1 114-1KA00-1BA1	3SF1 114-1KA00-1BA1	3SF1 114-1KA00-1BA1	3SF1 114-1KA00-1BA1	3SF1 114-1KA00-1BA1	3SF1 114-1KA00-1BA1	--	
				+ Actuator head	3SE5 000-0AC02	3SE5 000-0AD02	3SE5 000-0AE01	3SE5 000-0AE02	3SE5 000-0AF01	3SE5 000-0AF02	--			
		Snap action		Basic switch	3SF1 114-1LA00-1BA1	3SF1 114-1LA00-1BA1	3SF1 114-1LA00-1BA1	3SF1 114-1LA00-1BA1	3SF1 114-1LA00-1BA1	3SF1 114-1LA00-1BA1	3SF1 114-1LA00-1BA1	3SF1 114-1LA00-1BA1	3SF1 114-1LA00-1BA1	3SF1 114-1LA00-1BA1
				+ Actuator head	3SE5 000-0AC02	3SE5 000-0AD02	3SE5 000-0AE01	3SE5 000-0AE02	3SE5 000-0AF01	3SE5 000-0AF02	3SE5 000-0AR01			
56 mm wide	1 NC	Slow action	M12 plug, 4-pole; channel 1 on NC contact, channel 2 on M12 socket right	Basic switch	3SF1 124-1KA00-1BA2	3SF1 124-1KA00-1BA2	3SF1 124-1KA00-1BA2	3SF1 124-1KA00-1BA2	3SF1 124-1KA00-1BA2	3SF1 124-1KA00-1BA2	3SF1 124-1KA00-1BA2	3SF1 124-1KA00-1BA2	--	
				+ Actuator head	3SE5 000-0AC02	3SE5 000-0AD02	3SE5 000-0AE01	3SE5 000-0AE02	3SE5 000-0AF01	3SE5 000-0AF02	--			
		Snap action		Basic switch	3SF1 124-1LA00-1BA2	3SF1 124-1LA00-1BA2	3SF1 124-1LA00-1BA2	3SF1 124-1LA00-1BA2	3SF1 124-1LA00-1BA2	3SF1 124-1LA00-1BA2	3SF1 124-1LA00-1BA2	3SF1 124-1LA00-1BA2	3SF1 124-1LA00-1BA2	3SF1 124-1LA00-1BA2
				+ Actuator head	3SE5 000-0AC02	3SE5 000-0AD02	3SE5 000-0AE01	3SE5 000-0AE02	3SE5 000-0AF01	3SE5 000-0AF02	3SE5 000-0AR01			

For ordering notes see page 7.

# 3SF1 Standard Position Switches with Integrated ASIsafe Electronics

Module selection

## Plastic enclosures







Enclosure	Contacts	Contact element	Connection	Twist lever actuators (switching right and/or left, adjustable)										
				Metal levers		High-grade steel levers		Metal levers		Aluminum	Plastic			
				Plastic rollers	High-grade steel rollers	Plastic rollers	Plastic rollers	High-grade steel rollers	With latching holes, plastic rollers					
				↔ v <sub>max.</sub> = 1.5 m/s	↔ v <sub>max.</sub> = 1.5 m/s	↔ v <sub>max.</sub> = 1.5 m/s	↔ v <sub>max.</sub> = 1.5 m/s	↔ v <sub>max.</sub> = 1.5 m/s	↔ v <sub>max.</sub> = 1.5 m/s	↔ v <sub>max.</sub> = 1 m/s	↔ v <sub>max.</sub> = 1 m/s			
31 mm wide acc. to EN 50047	2 NC	Slow action	M12 plug, 4-pole; channel 1 on NC contact, channel 2 on NC contact	Basic switch	3SF1 234-1KC05-1BA1	3SF1 234-1KC05-1BA1	3SF1 234-1KC05-1BA1	3SF1 234-1KC05-1BA1	3SF1 234-1KC05-1BA1	3SF1 234-1KC05-1BA1	3SF1 234-1KC05-1BA1	--		
				+ Actuator head	3SE5 000-0AK00	3SE5 000-0AK00	3SE5 000-0AK00	3SE5 000-0AK00	3SE5 000-0AK00	3SE5 000-0AK00	3SE5 000-0AK00	3SE5 000-0AK00	3SE5 000-0AK00	
				+ Twist lever	3SE5 000-0AA21	3SE5 000-0AA22	3SE5 000-0AA31	3SE5 000-0AA50	3SE5 000-0AA51	3SE5 000-0AA60	3SE5 000-0AA80	3SE5 000-0AA82		
		Snap action		Basic switch	3SF1 234-1LC05-1BA1	3SF1 234-1LC05-1BA1	3SF1 234-1LC05-1BA1	3SF1 234-1LC05-1BA1	3SF1 234-1LC05-1BA1	3SF1 234-1LC05-1BA1	3SF1 234-1LC05-1BA1	3SF1 234-1LC05-1BA1	3SF1 234-1LC05-1BA1	3SF1 234-1LC05-1BA1
				+ Actuator head	3SE5 000-0AK00	3SE5 000-0AK00	3SE5 000-0AK00	3SE5 000-0AK00	3SE5 000-0AK00	3SE5 000-0AK00	3SE5 000-0AK00	3SE5 000-0AK00	3SE5 000-0AK00	
				+ Twist lever	3SE5 000-0AA21	3SE5 000-0AA22	3SE5 000-0AA31	3SE5 000-0AA50	3SE5 000-0AA51	3SE5 000-0AA60	3SE5 000-0AA80	3SE5 000-0AA82		
50 mm wide	2 NC	Slow action	M12 plug, 4-pole; channel 1 on NC contact, channel 2 on M12 socket right	Basic switch	3SF1 244-1KC05-1BA2	3SF1 244-1KC05-1BA2	3SF1 244-1KC05-1BA2	3SF1 244-1KC05-1BA2	3SF1 244-1KC05-1BA2	3SF1 244-1KC05-1BA2	3SF1 244-1KC05-1BA2	--		
				+ Actuator head	3SE5 000-0AK00	3SE5 000-0AK00	3SE5 000-0AK00	3SE5 000-0AK00	3SE5 000-0AK00	3SE5 000-0AK00	3SE5 000-0AK00	3SE5 000-0AK00		
				+ Twist lever	3SE5 000-0AA21	3SE5 000-0AA22	3SE5 000-0AA31	3SE5 000-0AA50	3SE5 000-0AA51	3SE5 000-0AA60	3SE5 000-0AA80	3SE5 000-0AA82		
		Snap action		Basic switch	3SF1 244-1LC05-1BA2	3SF1 244-1LC05-1BA2	3SF1 244-1LC05-1BA2	3SF1 244-1LC05-1BA2	3SF1 244-1LC05-1BA2	3SF1 244-1LC05-1BA2	3SF1 244-1LC05-1BA2	3SF1 244-1LC05-1BA2	3SF1 244-1LC05-1BA2	
				+ Actuator head	3SE5 000-0AK00	3SE5 000-0AK00	3SE5 000-0AK00	3SE5 000-0AK00	3SE5 000-0AK00	3SE5 000-0AK00	3SE5 000-0AK00	3SE5 000-0AK00		
				+ Twist lever	3SE5 000-0AA21	3SE5 000-0AA22	3SE5 000-0AA31	3SE5 000-0AA50	3SE5 000-0AA51	3SE5 000-0AA60	3SE5 000-0AA80	3SE5 000-0AA82		



## Metal enclosures









Enclosure	Contacts	Contact element	Connection	Twist lever actuators (switching right and/or left, adjustable)									
				Metal levers		High-grade steel levers		Metal levers		Aluminum	Plastic		
				Plastic rollers	High-grade steel rollers	Plastic rollers	Plastic rollers	High-grade steel rollers	With latching holes, plastic rollers				
				↔ v <sub>max.</sub> = 1.5 m/s	↔ v <sub>max.</sub> = 1.5 m/s	↔ v <sub>max.</sub> = 1.5 m/s	↔ v <sub>max.</sub> = 1.5 m/s	↔ v <sub>max.</sub> = 1.5 m/s	↔ v <sub>max.</sub> = 1.5 m/s	↔ v <sub>max.</sub> = 1 m/s	↔ v <sub>max.</sub> = 1 m/s		
40 mm wide acc. to EN 50041	2 NC	Slow action	M12 plug, 4-pole; channel 1 on NC contact, channel 2 on NC contact	Basic switch	3SF1 114-1KA00-1BA1	3SF1 114-1KA00-1BA1	3SF1 114-1KA00-1BA1	3SF1 114-1KA00-1BA1	3SF1 114-1KA00-1BA1	3SF1 114-1KA00-1BA1	3SF1 114-1KA00-1BA1	--	
				+ Actuator head	3SE5 000-0AH00	3SE5 000-0AH00	3SE5 000-0AH00	3SE5 000-0AH00	3SE5 000-0AH00	3SE5 000-0AH00	3SE5 000-0AH00	3SE5 000-0AH00	
				+ Twist lever	3SE5 000-0AA01	3SE5 000-0AA02	3SE5 000-0AA11	3SE5 000-0AA50	3SE5 000-0AA51	3SE5 000-0AA60	3SE5 000-0AA80	3SE5 000-0AA82	
		Snap action		Basic switch	3SF1 114-1LA00-1BA1	3SF1 114-1LA00-1BA1	3SF1 114-1LA00-1BA1	3SF1 114-1LA00-1BA1	3SF1 114-1LA00-1BA1	3SF1 114-1LA00-1BA1	3SF1 114-1LA00-1BA1	3SF1 114-1LA00-1BA1	3SF1 114-1LA00-1BA1
				+ Actuator head	3SE5 000-0AH00	3SE5 000-0AH00	3SE5 000-0AH00	3SE5 000-0AH00	3SE5 000-0AH00	3SE5 000-0AH00	3SE5 000-0AH00	3SE5 000-0AH00	
				+ Twist lever	3SE5 000-0AA01	3SE5 000-0AA02	3SE5 000-0AA11	3SE5 000-0AA50	3SE5 000-0AA51	3SE5 000-0AA60	3SE5 000-0AA80	3SE5 000-0AA82	
56 mm wide	2 NC	Slow action	M12 plug, 4-pole; channel 1 on NC contact, channel 2 on M12 socket right	Basic switch	3SF1 124-1KA00-1BA2	3SF1 124-1KA00-1BA2	3SF1 124-1KA00-1BA2	3SF1 124-1KA00-1BA2	3SF1 124-1KA00-1BA2	3SF1 124-1KA00-1BA2	3SF1 124-1KA00-1BA2	--	
				+ Actuator head	3SE5 000-0AH00	3SE5 000-0AH00	3SE5 000-0AH00	3SE5 000-0AH00	3SE5 000-0AH00	3SE5 000-0AH00	3SE5 000-0AH00	3SE5 000-0AH00	
				+ Twist lever	3SE5 000-0AA01	3SE5 000-0AA02	3SE5 000-0AA11	3SE5 000-0AA50	3SE5 000-0AA51	3SE5 000-0AA60	3SE5 000-0AA80	3SE5 000-0AA82	
		Snap action		Basic switch	3SF1 124-1LA00-1BA2	3SF1 124-1LA00-1BA2	3SF1 124-1LA00-1BA2	3SF1 124-1LA00-1BA2	3SF1 124-1LA00-1BA2	3SF1 124-1LA00-1BA2	3SF1 124-1LA00-1BA2	3SF1 124-1LA00-1BA2	
				+ Actuator head	3SE5 000-0AH00	3SE5 000-0AH00	3SE5 000-0AH00	3SE5 000-0AH00	3SE5 000-0AH00	3SE5 000-0AH00	3SE5 000-0AH00	3SE5 000-0AH00	
				+ Twist lever	3SE5 000-0AA01	3SE5 000-0AA02	3SE5 000-0AA11	3SE5 000-0AA50	3SE5 000-0AA51	3SE5 000-0AA60	3SE5 000-0AA80	3SE5 000-0AA82	

For ordering notes see page 7.

3SF1 position switches with separate actuator and ASIsafe; complete units				
Contacts	Contact elements	Version	LED display	Order No.
Plastic enclosures according to EN 50047 (31 mm wide), 5 directions of approach				
2 NC 	Slow action →	M12 plug, 4-pole; channel 1 on NC contact, channel 2 on NC contact	ASI status, F-In1, F-In2	3SF1 234-1QV40-1BA1
Plastic enclosures (50 mm wide), 5 directions of approach				
1 NC 	Slow action →	M12 plug, 4-pole, left channel 1 on NC contact, channel 2 on M12 socket right	ASI status, F-In1, F-In2	3SF1 244-1QV40-1BA2
Metal enclosures according to EN 50041 (40 mm wide), 5 directions of approach				
2 NC 	Slow action →	M12 plug, 4-pole; channel 1 on NC contact, channel 2 on NC contact	ASI status, F-In1, F-In2	3SF1 114-1QV10-1BA1
Metal enclosures (56 mm wide), 5 directions of approach				
1 NC 	Slow action →	M12 plug, 4-pole, bottom channel 1 on NC contact, channel 2 on M12 socket right	ASI status, F-In1, F-In2	3SF1 124-1QV10-1BA2

Actuators for 3SE5/3SF1 position switches with separate actuator/tumbler and ASIsafe		
	Standard actuators	3SE5 000-0AV01
	Actuators with vertical fixing	3SE5 000-0AV02
	Actuators with transverse fixing	3SE5 000-0AV03
	Radius actuators, left	3SE5 000-0AV04
	Radius actuators, right	3SE5 000-0AV06
	Universal radius actuators	3SE5 000-0AV05

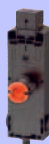
The actuators are not included in the scope of supply of the switch and must be ordered separately.

3SF1 position switches with separate actuator and ASIsafe, <sup>1)</sup> complete units					
Version	Release	Magnet voltage	LED display	Plastic enclosure, M12 plug, 4-pole Order No.	Metal enclosure, M12 plug, 4-pole Order No.
Spring-actuated lock (closed-circuit principle) Channel 1 on NC contact actuator, channel 2 on NC contact magnet	Auxiliary release 	24 V DC	ASI status, (F-In1, F-In2, ASI, Fault)	3SF1 324-1SD21-1BA1	3SF1 314-1SD11-1BA1
	Auxiliary release with lock 			3SF1 324-1SE21-1BA1	3SF1 314-1SE11-1BA1
	Escape release from the front 			3SF1 324-1SF21-1BA1	3SF1 314-1SF11-1BA1
	Escape release from the back, auxiliary release from the front  (Rear view)			3SF1 324-1SG21-1BA1	3SF1 314-1SG11-1BA1
	Emergency release from the back, emergency release from the front  (Rear view)			3SF1 324-1SJ21-1BA1	3SF1 314-1SJ11-1BA1
Spring-actuated lock (closed-circuit principle) Channel 1 and 2 on NC contact of the actuator	Auxiliary release 	24 V DC	ASI status, (F-In1, F-In2, ASI, Fault)	3SF1 324-1SD21-1BA3	--
Magnet field lock (open-circuit principle) Channel 1 on NC contact actuator, channel 2 on NC contact magnet		24 V DC	ASI status, (F-In1, F-In2, ASI, Fault)	3SF1 324-1SB21-1BA1	3SF1 314-1SB11-1BA1

1) For actuators see page 38.

# Position Switches with Solenoid Interlocking

## ASI-Safe application Cat. 3 according to EN 954-1

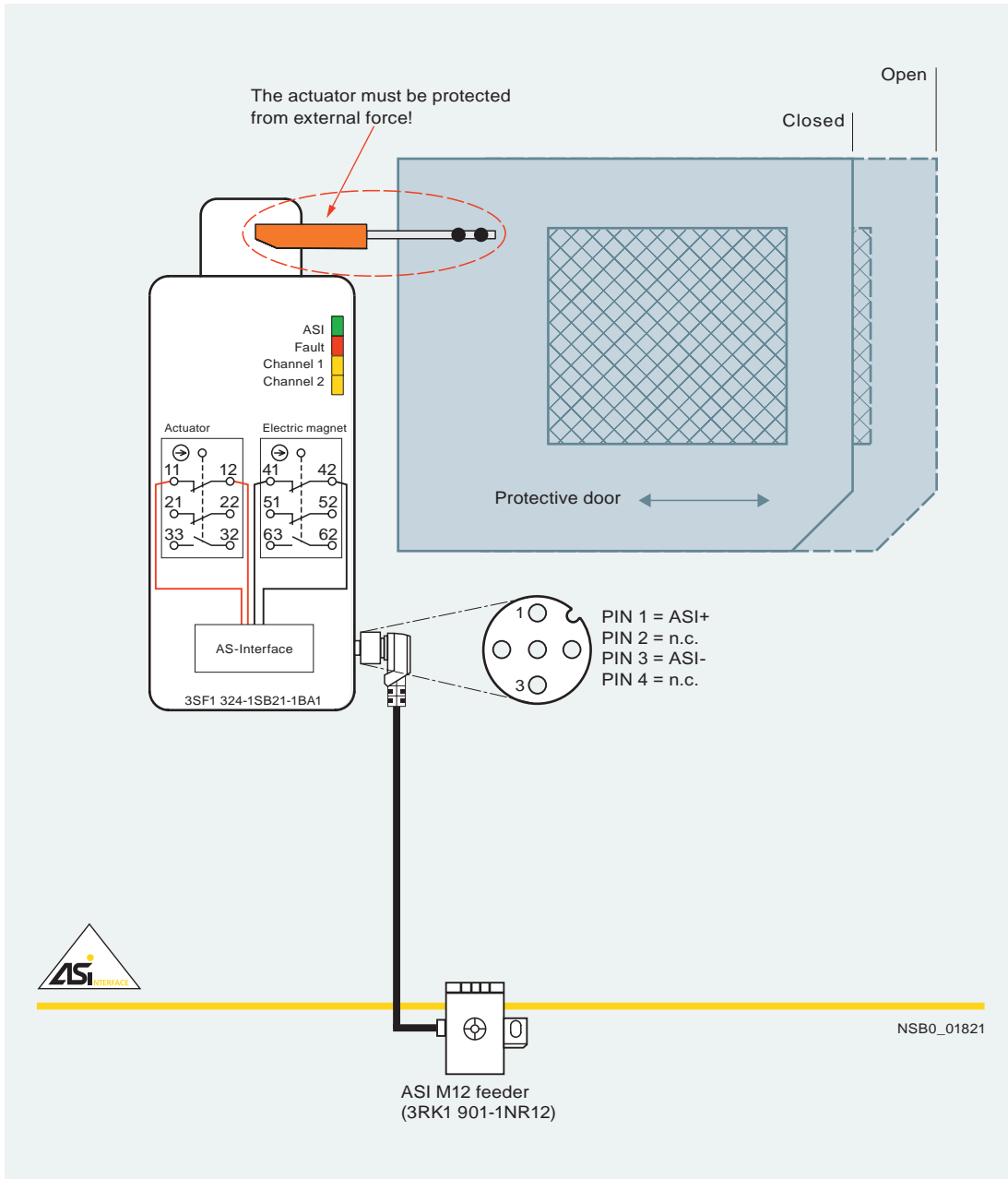

## 3SF1 hinge switches with ASIsafe, complete units

Contacts (snap-action contact element)	Connection					
		Hollow shaft $\varnothing_{\text{int.}} = 8 \text{ mm}$ , $\varnothing_{\text{ext.}} = 12 \text{ mm}$		Solid shaft $\varnothing 10 \text{ mm}$		
		Switching point 5° 	Switching point 15° 	Switching point 5° 	Switching point 15° 	
Plastic enclosures, 31 mm wide according to EN50047						
 2 NC	M12 plug, 4-pole; channel 1 on NC contact, channel 2 on NC contact	Basic switch	3SF1 234-1LC05-1BA1	3SF1 234-1LC05-1BA1	3SF1 234-1LC05-1BA1	3SF1 234-1LC05-1BA1
		+ Actuator head	3SE5 000-0AU11	3SE5 000-0AU21	3SE5 000-0AU12	3SE5 000-0AU22
Plastic enclosures, 50 mm wide						
 1 NC	M12 plug, 4-pole; channel 1 on NC contact, channel 2 on M12 socket right	Basic switch	3SF1 244-1LC05-1BA2	3SF1 244-1LC05-1BA2	3SF1 244-1LC05-1BA2	3SF1 244-1LC05-1BA2
		+ Actuator head	3SE5 000-0AU11	3SE5 000-0AU21	3SE5 000-0AU12	3SE5 000-0AU22
Metal enclosures, 40 mm wide according to EN 50041						
 2 NC	M12 plug, 4-pole; channel 1 on NC contact, channel 2 on NC contact	Basic switch	3SF1 114-1LA00-1BA1	3SF1 114-1LA00-1BA1	3SF1 114-1LA00-1BA1	3SF1 114-1LA00-1BA1
		+ Actuator head	3SE5 000-0AU11	3SE5 000-0AU21	3SE5 000-0AU12	3SE5 000-0AU22
Metal enclosures, 56 mm wide						
 1 NC	M12 plug, 4-pole; channel 1 on NC contact, channel 2 on M12 socket right	Basic switch	3SF1 124-1LA00-1BA2	3SF1 124-1LA00-1BA2	3SF1 124-1LA00-1BA2	3SF1 124-1LA00-1BA2
		+ Actuator head	3SE5 000-0AU11	3SE5 000-0AU21	3SE5 000-0AU12	3SE5 000-0AU22

## SIRIUS Position Switches according to ATEX 95:

In many industries the production, processing, transport and storage of combustible substances are accompanied by escaping gases, vapor or spray which find their way into the environment. Other processes result in combustible dust. Together with the oxygen in the air, the result can be an explosive atmosphere (in French: ATmosphère EXplosive) which will explode if ignited.

To guarantee the maximum possible safety in these areas, the legislators of most countries have drawn up requirements in the form of laws, regulations and standards which our switches comply with to the letter.

In explosion-protected areas and misty or dusty environments we recommend the use of our position switches according to ATEX 95. These variants comply with Directive 94/4/EG || 3D, ATEX 95 of the European Union and are approved for Zone 22.

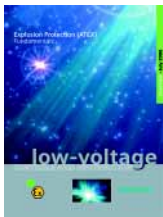





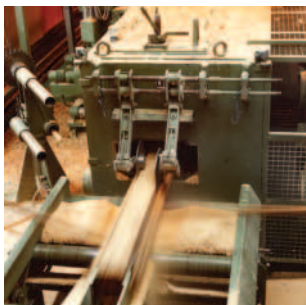

For more information about ATEX we recommend our brochure:

Explosion Protection (ATEX) Fundamentals  
Order No.: E86060-T1811-A101-A1-7600







### 3SE5 hinge switches, complete units

Contacts (snap-action contact element)	Connection				
		Hollow shaft $\varnothing_{\text{int.}} = 8 \text{ mm}$ , $\varnothing_{\text{ext.}} = 12 \text{ mm}$		Solid shaft $\varnothing = 10 \text{ mm}$	
		Operating angle 5° 	Operating angle 15° 	Operating angle 5° 	Operating angle 15° 
Metal enclosures according to EN 50041 (40 mm wide), mounting on hinges, ATEX Zone 22					
1 NO/2 NC 	1 x (M20 x 1.5)	3SE5 112-0LU11-1DA0	3SE5 112-0LU21-1DA0	3SE5 112-0LU12-1DA0	3SE5 112-0LU22-1DA0

### 3SE5 position switches with separate actuator, complete units

Version	Contacts (slow-action contact)	Connection	LED display	Order No.	
Metal enclosures, ATEX Zone 22, 5 directions of approach					
	40 mm wide (EN 50041)	1 NO/2 NC 	1 x (M20 x 1.5)	without	3SE5 112-0QV10-1DA0
	56 mm wide	1 NO/2 NC 	3 x (M20 x 1.5)	without	3SE5 122-0QV10-1DA0

### Actuators for 3SE5 position switches with separate actuator

	Standard actuators	3SE5 000-0AV01
	Actuators with vertical fixing	3SE5 000-0AV02
	Actuators with transverse fixing	3SE5 000-0AV03
	Radius actuators, left	3SE5 000-0AV04
	Radius actuators, right	3SE5 000-0AV06
	Universal radius actuators	3SE5 000-0AV05

The actuators are not included in the scope of supply of the switch and must be ordered separately.

### 3SE5 Standard Position Switches according to ATEX 95, Zone 22 Metal Enclosures

Complete unit and Module selection

Rounded plungers	Roller plungers	Roller levers	Angular roller levers	Spring rod actuators	Twist lever actuators (switching right and/or left, adjustable)			
								
High-grade steel, with overtravel ↓ $v_{max.} = 1 \text{ m/s}$	High-grade steel rollers ↔ $v_{max.} = 1 \text{ m/s}$	High-grade steel levers, plastic rollers ↔ $v_{max.} = 1 \text{ m/s}$	High-grade steel levers, plastic rollers ← $v_{max.} = 1 \text{ m/s}$	Plastic plungers, total length 143 mm $v_{max.} = 1 \text{ m/s}$	EN 50041 High-grade steel levers, plastic rollers ↔ $v_{max.} = 1.5 \text{ m/s}$	High-grade steel levers With latching holes, plastic rollers $v_{max.} = 1.5 \text{ m/s}$	Rod actuators, 200 mm long Aluminum ↔ $v_{max.} = 3 \text{ m/s}$ Plastic ↔ $v_{max.} = 3 \text{ m/s}$	



Enclosure	Contacts	Contact element		Rounded plungers	Roller plungers	Roller levers	Angular roller levers	Spring rod actuators	Twist lever actuators (switching right and/or left, adjustable)	Aluminum	Plastic	
Metal enclosure according to EN 50041, (40 mm wide), 1 x M20 x 1.5)	1 NO/ 1 NC	Slow action	Complete unit	--	--	--	--	--	--	--	--	
			Basic switch	3SE5 112-0BA00-1DA0	3SE5 112-0BA00-1DA0	3SE5 112-0BA00-1DA0	3SE5 112-0BA00-1DA0	3SE5 112-0BA00-1DA0	3SE5 112-0BA00-1DA0	3SE5 112-0BA00-1DA0	3SE5 112-0BA00-1DA0	3SE5 112-0BA00-1DA0
			+ Actuator head	3SE5 000-0AC02	3SE5 000-0AD02	3SE5 000-0AE03	3SE5 000-0AF03	3SE5 000-0AR01	3SE5 000-0AH00	3SE5 000-0AH00	3SE5 000-0AH00	3SE5 000-0AH00
		+ Twist lever	--	--	--	--	--	3SE5 000-0AA11	3SE5 000-0AA60	3SE5 000-0AA80	3SE5 000-0AA82	
		Snap action	Complete unit	3SE5 112-0CC02-1DA0	3SE5 112-0CD02-1DA0	3SE5 112-0CE03-1DA0	3SE5 112-0CF03-1DA0	3SE5 112-0CR01-1DA0	3SE5 112-0CH11-1DA0	--	--	--
			Basic switch	3SE5 112-0CA00-1DA0	3SE5 112-0CA00-1DA0	3SE5 112-0CA00-1DA0	3SE5 112-0CA00-1DA0	3SE5 112-0CA00-1DA0	3SE5 112-0CA00-1DA0	3SE5 112-0CA00-1DA0	3SE5 112-0CA00-1DA0	3SE5 112-0CH80-1DA0
	+ Actuator head		3SE5 000-0AC02	3SE5 000-0AD02	3SE5 000-0AE03	3SE5 000-0AF03	3SE5 000-0AR01	3SE5 000-0AH00	3SE5 000-0AH00	3SE5 000-0AH00	3SE5 000-0AH00	
	1 NO/ 2 NC	Slow action	Complete unit	--	--	--	--	--	--	--	--	
			Basic switch	3SE5 112-0KA00-1DA0	3SE5 112-0KA00-1DA0	3SE5 112-0KA00-1DA0	3SE5 112-0KA00-1DA0	3SE5 112-0KA00-1DA0	3SE5 112-0KA00-1DA0	3SE5 112-0KA00-1DA0	3SE5 112-0KA00-1DA0	3SE5 112-0KA00-1DA0
			+ Actuator head	3SE5 000-0AC02	3SE5 000-0AD02	3SE5 000-0AE03	3SE5 000-0AF03	3SE5 000-0AR01	3SE5 000-0AH00	3SE5 000-0AH00	3SE5 000-0AH00	3SE5 000-0AH00
		+ Twist lever	--	--	--	--	--	3SE5 000-0AA11	3SE5 000-0AA60	3SE5 000-0AA80	3SE5 000-0AA82	
		Snap action	Complete unit	--	--	--	--	--	--	--	--	
Basic switch			3SE5 112-0LA00-1DA0	3SE5 112-0LA00-1DA0	3SE5 112-0LA00-1DA0	3SE5 112-0LA00-1DA0	3SE5 112-0LA00-1DA0	3SE5 112-0LA00-1DA0	3SE5 112-0LA00-1DA0	3SE5 112-0LA00-1DA0	3SE5 112-0LA00-1DA0	
+ Actuator head	3SE5 000-0AC02		3SE5 000-0AD02	3SE5 000-0AE03	3SE5 000-0AF03	3SE5 000-0AR01	3SE5 000-0AH00	3SE5 000-0AH00	3SE5 000-0AH00	3SE5 000-0AH00		
Metal enclosure (56 mm wide), 3 x (M20 x 1.5)	1 NO/ 1 NC	Slow action	Complete unit	--	--	--	--	--	--	--	--	
			Basic switch	3SE5 122-0BA00-1DA0	3SE5 122-0BA00-1DA0	3SE5 122-0BA00-1DA0	3SE5 122-0BA00-1DA0	3SE5 122-0BA00-1DA0	3SE5 122-0BA00-1DA0	3SE5 122-0BA00-1DA0	3SE5 122-0BA00-1DA0	3SE5 122-0BA00-1DA0
			+ Actuator head	3SE5 000-0AC02	3SE5 000-0AD02	3SE5 000-0AE03	3SE5 000-0AF03	3SE5 000-0AR01	3SE5 000-0AH00	3SE5 000-0AH00	3SE5 000-0AH00	3SE5 000-0AH00
		+ Twist lever	--	--	--	--	--	3SE5 000-0AA11	3SE5 000-0AA60	3SE5 000-0AA80	3SE5 000-0AA82	
		Snap action	Complete unit	3SE5 122-0CC02-1DA0	3SE5 122-0CD02-1DA0	3SE5 122-0CE03-1DA0	3SE5 122-0CF03-1DA0	3SE5 122-0CR01-1DA0	3SE5 122-0CH11-1DA0	--	--	
			Basic switch	3SE5 122-0CA00-1DA0	3SE5 122-0CA00-1DA0	3SE5 122-0CA00-1DA0	3SE5 122-0CA00-1DA0	3SE5 122-0CA00-1DA0	3SE5 122-0CA00-1DA0	3SE5 122-0CA00-1DA0	3SE5 122-0CA00-1DA0	3SE5 122-0CA00-1DA0
	+ Actuator head		3SE5 000-0AC02	3SE5 000-0AD02	3SE5 000-0AE03	3SE5 000-0AF03	3SE5 000-0AR01	3SE5 000-0AH00	3SE5 000-0AH00	3SE5 000-0AH00	3SE5 000-0AH00	
	1 NO/ 2 NC	Slow action	Complete unit	--	--	--	--	--	--	--	--	
			Basic switch	3SE5 122-0KA00-1DA0	3SE5 122-0KA00-1DA0	3SE5 122-0KA00-1DA0	3SE5 122-0KA00-1DA0	3SE5 122-0KA00-1DA0	3SE5 122-0KA00-1DA0	3SE5 122-0KA00-1DA0	3SE5 122-0KA00-1DA0	3SE5 122-0KA00-1DA0
			+ Actuator head	3SE5 000-0AC02	3SE5 000-0AD02	3SE5 000-0AE03	3SE5 000-0AF03	3SE5 000-0AR01	3SE5 000-0AH00	3SE5 000-0AH00	3SE5 000-0AH00	3SE5 000-0AH00
		+ Twist lever	--	--	--	--	--	3SE5 000-0AA11	3SE5 000-0AA60	3SE5 000-0AA80	3SE5 000-0AA82	
		Snap action	Complete unit	--	--	--	--	--	--	--	--	
Basic switch			3SE5 122-0LA00-1DA0	3SE5 122-0LA00-1DA0	3SE5 122-0LA00-1DA0	3SE5 122-0LA00-1DA0	3SE5 122-0LA00-1DA0	3SE5 122-0LA00-1DA0	3SE5 122-0LA00-1DA0	3SE5 122-0LA00-1DA0	3SE5 122-0LA00-1DA0	
+ Actuator head	3SE5 000-0AC02		3SE5 000-0AD02	3SE5 000-0AE03	3SE5 000-0AF03	3SE5 000-0AR01	3SE5 000-0AH00	3SE5 000-0AH00	3SE5 000-0AH00	3SE5 000-0AH00		
+ Twist lever	--	--	--	--	--	3SE5 000-0AA11	3SE5 000-0AA60	3SE5 000-0AA80	3SE5 000-0AA82			



# Notes





## SIRIUS Controls

CONTROLS

 SIRIUS Solid-State Switching Devices

PROTECTING

 SIRIUS Infeed System

 Configuring SIRIUS Load Feeders

 SIRIUS Soft Starters

 SIMATIC ET 200pro

 SIRIUS Motor Starters

STARTING

MONITORING AND CONTROL

 SIRIUS Motor Management System SIMOCODE pro

 SIRIUS Relays

 SIRIUS Safety Relays

DETECTION

 SIRIUS Position Switches

 SIMATIC Sensor Technology

COMMANDING AND SIGNALING

 SIRIUS Pushbuttons and Indicator Lights

 SIRIUS Signaling Columns and Integrated Signal Lamps

 SIRIUS Cable-Operated Switches

SUPPLY

 SIRIUS Fans

 SIDAC Reactors & Filters

 SIDAC & SIVENT Solutions

ENGINEERING

 Switch ES Motor Starters

 SIMOCODE ES

 Soft Starter ES

SIRIUS AND MORE

 SIRIUS Safety Integrated

 AS-Interface

 SIRIUS Connection Method

 ECOFAST

 SIRIUS Modular System

### Newsletter

Always up-to date: Our regular newsletter brings you up-to-date information about industrial controls and power distribution. You can sign up for it at:

[www.siemens.com/lowvoltage/newsletter](http://www.siemens.com/lowvoltage/newsletter)

Please send the selected information to the following address:

Company/Department

Name

Street, ZIP/Town, Country

Telephone/Fax

E-Mail

### Siemens AG

Automation and Drives  
Low-Voltage Controls and Distribution  
Postfach 48 48  
90327 NÜRNBERG  
GERMANY

[www.siemens.com/lowvoltage/technical-assistance](http://www.siemens.com/lowvoltage/technical-assistance)  
[www.siemens.com/sirius](http://www.siemens.com/sirius)

The information provided in this brochure contains descriptions or characteristics of performance which in case of actual use do not always apply as described or which may change as a result of further development of the products. An obligation to provide the respective characteristics shall only exist if expressly agreed in the terms of contract. Availability and technical specifications are subject to change without notice.

All product designations may be trademarks or product names of Siemens AG or supplier companies whose use by third parties for their own purposes could violate the rights of the owners.

Order No. E86060-T1812-A101-A3-7600

Token fee: 0.00 €